

ITEM	PART No.	DESCRIPTION	Qty.
1	DM3254	REGULATOR PRESSURE TEST KIT	1
2	DM32580	FLOWMETER ASSEMBLY	1
3	DM32570	MANOMETER ASSEMBLY	1
4	SM034	CHRISTO-LUBE GREASE	1
5	M2920	LOCKNUT SPANNER	1
6	M2921B	DUCT SPANNER	1
7	M2922	DEMAND VALVE ACTUATING TOOL	1
8	TA097	TOOL, SPANNER, COMBINATION, 5/16" AF	1
9	MC328	STORAGE CASE	1
10	D311	IN/EXHALE DUCT PROTECTION COVER ASSEMBLY	3
11	TA024	ALLEN KEY (3/32")	1
12	TA182	ALLEN KEY (1/16")	1
13	TA009	STRAP WRENCH	1
14	T1087	LABEL, SLS TOOL & INSTRUMENT SET	1

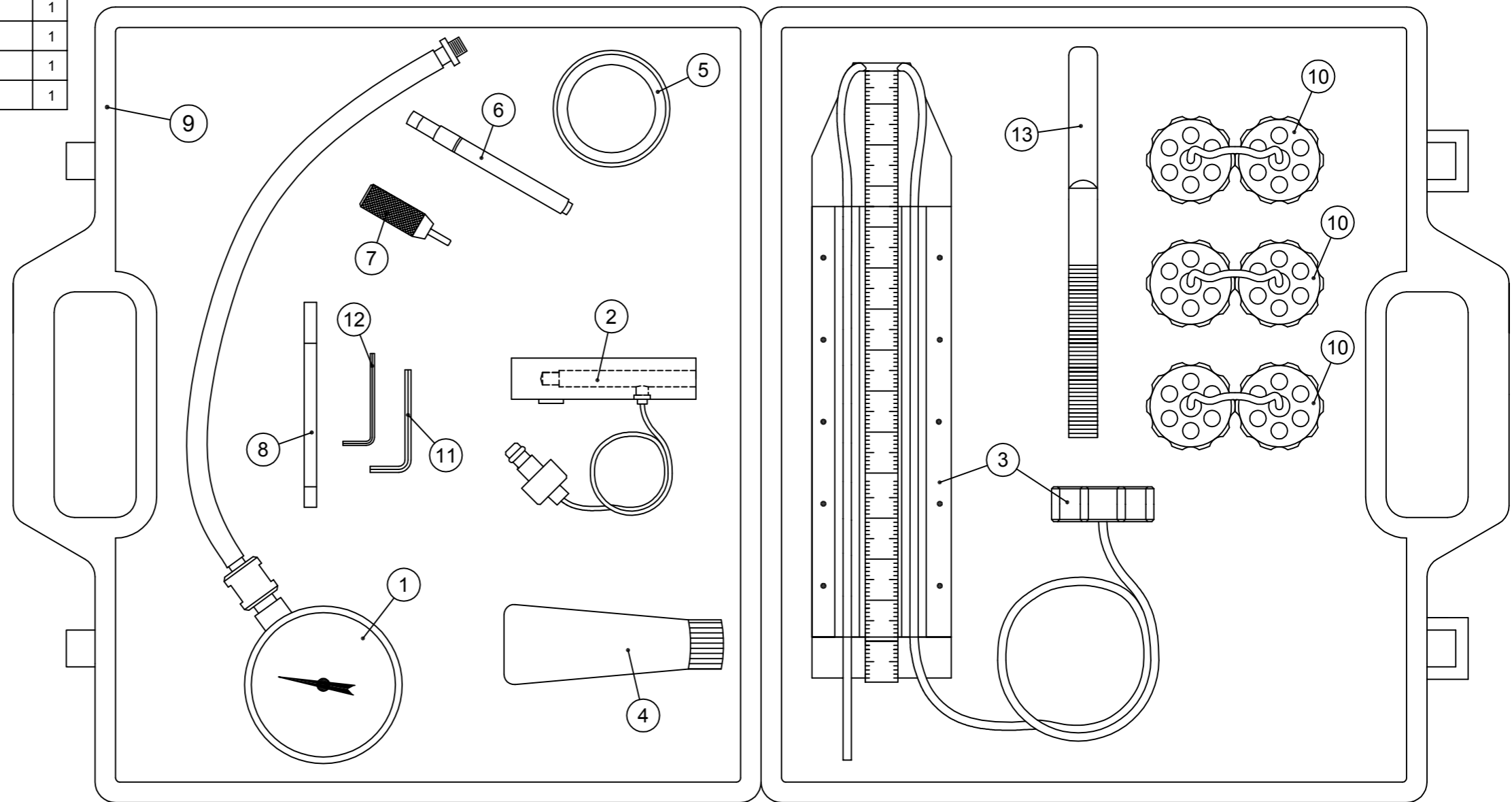

DIVEX OWNS THE COPYRIGHT OF THIS DOCUMENT AND ANY DESIGN RIGHT HEREIN. IT IS SUPPLIED IN CONFIDENCE AND MUST NOT BE USED FOR ANY PURPOSE OTHER THAN THAT FOR WHICH IT IS SUPPLIED AND MUST NOT BE REPRODUCED WITHOUT PERMISSION IN WRITING FROM THE OWNERS.

NOTES ITEM 14 TO BE POSITIONED CENTRALLY ON THE FRONT OF THE BOX. (ITEM NOT SHOWN)	ALL DIMENSIONS SHOWN ARE IN MM (UOS) ALL DIMENSIONS BEFORE PLATING (UOS) REMOVE ALL SHARP EDGES AND BURRS	MATERIAL SEE PARTS LIST	<table border="1"> <tr><td>R07</td><td></td><td></td><td></td><td></td><td></td></tr> <tr><td>R06</td><td></td><td></td><td></td><td></td><td></td></tr> <tr><td>R05</td><td>ITEM No. 10 REPOSITIONED & BOM ADDED</td><td>13073</td><td>SJ</td><td>01/12/2009</td><td>RTW</td></tr> <tr><td>R04</td><td>ITEM No. 14 ADDED</td><td>5228</td><td>PW</td><td>23/09/2004</td><td>RTW</td></tr> <tr><td>R03</td><td>LAYOUT REVISED</td><td>4807</td><td>JG</td><td>01/03/2004</td><td>RTW</td></tr> <tr><td>R02</td><td>ITEM No. 8 REVISED</td><td>4544</td><td>JG</td><td>09/10/2003</td><td>RTW</td></tr> <tr><td>R00</td><td>ISSUED FOR MANUFACTURE</td><td></td><td>IHY</td><td>24/05/1996</td><td>DRS</td></tr> <tr><td>REV</td><td>DESCRIPTION</td><td>ECN No</td><td>BY</td><td>DATE</td><td>AUTH. BY</td></tr> </table>	R07						R06						R05	ITEM No. 10 REPOSITIONED & BOM ADDED	13073	SJ	01/12/2009	RTW	R04	ITEM No. 14 ADDED	5228	PW	23/09/2004	RTW	R03	LAYOUT REVISED	4807	JG	01/03/2004	RTW	R02	ITEM No. 8 REVISED	4544	JG	09/10/2003	RTW	R00	ISSUED FOR MANUFACTURE		IHY	24/05/1996	DRS	REV	DESCRIPTION	ECN No	BY	DATE	AUTH. BY	TITLE TOOL & TEST KIT LAYOUT
	R07																																																			
R06																																																				
R05	ITEM No. 10 REPOSITIONED & BOM ADDED	13073	SJ	01/12/2009	RTW																																															
R04	ITEM No. 14 ADDED	5228	PW	23/09/2004	RTW																																															
R03	LAYOUT REVISED	4807	JG	01/03/2004	RTW																																															
R02	ITEM No. 8 REVISED	4544	JG	09/10/2003	RTW																																															
R00	ISSUED FOR MANUFACTURE		IHY	24/05/1996	DRS																																															
REV	DESCRIPTION	ECN No	BY	DATE	AUTH. BY																																															
<table border="1"> <tr> <th colspan="2">DIMENSIONAL TOLERANCES</th> <th colspan="2">MACHINING</th> <th colspan="2">FABRICATION</th> </tr> <tr> <td>NO DECIMAL PLACES</td> <td>±1.0</td> <td>SIZE >0 <100</td> <td>±0.5</td> <td>SIZE >100 <500</td> <td>±1.5</td> </tr> <tr> <td>ONE DECIMAL PLACE</td> <td>±0.2</td> <td>SIZE >500</td> <td>±3.0</td> <td>ANGULAR TOLERANCE</td> <td>±0.5°</td> </tr> <tr> <td>TWO DECIMAL PLACE</td> <td>±0.05</td> <td></td> <td></td> <td></td> <td></td> </tr> <tr> <td>ANGULAR TOLERANCE</td> <td>±0.5°</td> <td></td> <td></td> <td></td> <td></td> </tr> </table>	DIMENSIONAL TOLERANCES		MACHINING		FABRICATION		NO DECIMAL PLACES	±1.0	SIZE >0 <100	±0.5	SIZE >100 <500	±1.5	ONE DECIMAL PLACE	±0.2	SIZE >500	±3.0	ANGULAR TOLERANCE	±0.5°	TWO DECIMAL PLACE	±0.05					ANGULAR TOLERANCE	±0.5°					FINISH -	<table border="1"> <tr> <td>DRAWING No.</td> <td>REV</td> </tr> <tr> <td>P1939204S1</td> <td>R05</td> </tr> <tr> <td>PART No.</td> <td>PRODUCT / PROJECT No.</td> </tr> <tr> <td>C10203</td> <td>SLS SYSTEM</td> </tr> </table>	DRAWING No.	REV	P1939204S1	R05	PART No.	PRODUCT / PROJECT No.	C10203	SLS SYSTEM	<table border="1"> <tr> <td>SIZE</td> <td>SCALE</td> <td>SHT</td> <td>OF</td> </tr> <tr> <td>A2</td> <td>NTS</td> <td>1</td> <td>1</td> </tr> </table>	SIZE	SCALE	SHT	OF	A2	NTS	1	1			
DIMENSIONAL TOLERANCES		MACHINING		FABRICATION																																																
NO DECIMAL PLACES	±1.0	SIZE >0 <100	±0.5	SIZE >100 <500	±1.5																																															
ONE DECIMAL PLACE	±0.2	SIZE >500	±3.0	ANGULAR TOLERANCE	±0.5°																																															
TWO DECIMAL PLACE	±0.05																																																			
ANGULAR TOLERANCE	±0.5°																																																			
DRAWING No.	REV																																																			
P1939204S1	R05																																																			
PART No.	PRODUCT / PROJECT No.																																																			
C10203	SLS SYSTEM																																																			
SIZE	SCALE	SHT	OF																																																	
A2	NTS	1	1																																																	

DO NOT SCALE DRAWING

DIVEX LIMITED
 ENTERPRISE DRIVE
 WESTHILL
 ABERDEEN
 AB32 6TQ
 UNITED KINGDOM
 Tel: +44(0)1224 740145
 Fax: +44(0)1224 740172
 email: info@divexglobal.com
 www.divexglobal.com