

**OPERATION & MAINTENANCE  
MANUAL**

for the

**TWO DIVER, SURFACE CONTROL,  
HP/LP AIR/ COMMUNICATION PANEL  
IN TRANSIT CASE**

**6 JIC LP Panel Connections  
4 JIC HP Panel Connections  
Part No: PP032AC**





THIS PAGE IS LEFT BLANK INTENTIONALLY



**DIVEX LTD**

**DOCUMENT NUMBER:** OM 341

**ISSUE No:** 1

**DOCUMENT TITLE:** TWO DIVER, SURFACE CONTROL, HP/LP AIR COMMUNICATIONS PANEL, IN TRANSIT CASE

REV	DATE	BY	CHK	APP	COMMENTS
0	23/12/02	FB	JM	RW	ORIGINAL ISSUE
1	06/10/03	LL	JM	JM	ECN 4526
2	22/09/10	SMCM	<i>R. Wylie</i>	<i>R. Wylie</i>	ECN 13641
3					
4					
5					
6					
7					

**ORIGINAL ISSUE DATE:** 23/12/02

**ORIGINAL DOCUMENT BY:** F. Bain

**CHECKED BY:** J. Massie

**APPROVED BY:** R. Wylie



THIS PAGE IS LEFT BLANK INTENTIONALLY



## CONTENTS

- 1.0 SAFETY NOTICE
- 2.0 TECHNICAL SPECIFICATION
- 3.0 GENERAL DESCRIPTION
- 4.0 INSTALLATION
- 5.0 PRE-DIVE CHECK
- 6.0 OPERATION
- 7.0 PNEUMO OPERATION
- 8.0 CYLINDER CHANGE OVER
- 9.0 LOW PRESSURE INLET
- 10.0 LOW H.P. WARNING
- 11.0 MAINTENANCE
- 12.0 MAINTENANCE SCHEDULE
- 13.0 DIVER COMMUNICATIONS
- 14.0 TAPE RECORDER
- 15.0 APPENDICES

<b>DRAWINGS: PP032004</b>	<b>Fit-Out Schematic</b>
<b>PP032109</b>	<b>Diver Air Panel Assembly</b>
<b>PP032102</b>	<b>Comms Panel Assembly</b>
<b>U1011</b>	<b>H.P. Control Valve Spare Parts</b>



THIS PAGE IS LEFT BLANK INTENTIONALLY



## **1.0 SAFETY NOTICE**

- 1.1 This unit must only be operated by suitably qualified personnel.
- 1.2 Read the instructions thoroughly before operating this equipment.
- 1.3 Only genuine manufacturer's spare parts may be used and the substitution of parts from other manufacturers will invalidate the warranty and may cause damage to the equipment. When ordering spare parts, please quote the serial number of the assembly and the part numbers required.
- 1.4 This panel has been designed to supply air to breathing apparatus, for diving, and the manufacturers will not be responsible for its use for any other purpose.
- 1.5 The user must make him/herself familiar with and observe national legal requirements concerning the safe use and maintenance of the equipment. The manufacturers ensure that the equipment complies with such regulations on delivery but it remains the responsibility of the user to comply with the legal requirements in use.
- 1.6 It is the responsibility of the user to establish the flow and pressure of air required for the breathing apparatus to be employed and to ensure that the supply is adequate for the use envisaged. This responsibility includes the provision of an adequate reserve air supply.

**COMPRESSED AIR IS POTENTIALLY DANGEROUS**

**THIS EQUIPMENT MUST BE USED CORRECTLY**

**MISUSE COULD CAUSE SERIOUS INJURY**



THIS PAGE IS LEFT BLANK INTENTIONALLY





## 2.0 TECHNICAL SPECIFICATION

2.1	Inlet Pressure	L.P. 15 BAR maximum (220 psi) H.P. 350 BAR maximum (5075 psi)
2.2	Hose Connections	LP inlet      No.6 JIC male HP inlet      No.4 JIC male Diver supply No.6 JIC male Pneumo      No.4 JIC male
2.3	Overall External Dimensions	Length      730 mm (29") Width      610 mm (24") Height      380 mm (16")  Weight approximately 40 kg (88lbs)
2.4	Pipework	6mm x 1mm stainless steel 8mm x 1mm stainless steel 10mm x 1mm stainless steel



THIS PAGE IS LEFT BLANK INTENTIONALLY



### 3.0 GENERAL DESCRIPTION

- 3.1 The **DIVEX** two-diver, Surface Control, H.P./L.P. air panel will supply low pressure breathing air to two divers working simultaneously, to a depth of 60 metres in fresh or salt water.
- 3.2 The panel contains four completely separate high pressure lines, two for each diver. Non-return valves ensure that the air to one diver cannot be diverted to the other. As a back-up, one L.P. inlet line is fitted, which can supply either diver with air.
- 3.3 Each diver's depth can be monitored using the pneumo gauges which measure the hydrostatic pressure in an open ended hose from the panel to each diver.
- 3.4 The controls are packaged within a strong plastic transit case.



THIS PAGE IS LEFT BLANK INTENTIONALLY



## 4.0 INSTALLATION

(Refer to Drawings PP032109 & PP032102).

Using a high pressure air supply.

- 4.1 Ensure all on/off valves are in the **OFF** position.
- 4.2 Ensure the H.P. / L.P. regulator controls are turned fully anti-clockwise.
- 4.3 Connect the H.P. hose assembly to the high pressure air cylinders, ensuring that the cylinder valves remain in the **OFF** position.
- 4.4 Connect the diver's air line from the umbilical to the diver's L.P. outlet on the panel.
- 4.5 Connect the diver's pneumo hose from the umbilical to the panel pneumo connection.
- 4.6 Connect the diver's end of the umbilical to the appropriate breathing apparatus.
- 4.7 Connect the divers communications interconnection adaptor to the communication panel and attach the umbilical as per the umbilical instructions.



THIS PAGE IS LEFT BLANK INTENTIONALLY



## 5.0 PRE-DIVE CHECK

(Refer to drawing PP032109)

- 5.1 With all lines connected and the diver dressed in all his equipment but holding the face/mask helmet, turn on the H.P. cylinder.
- 5.2 Turn on the H.P. inlet valve slowly (3).
- 5.3 Read the H.P. inlet pressure (4). Ensure that there is adequate cylinder pressure.
- 5.4 Use the H.P./ L.P. regulator (1) to set the correct L.P. pressure for the diver's breathing apparatus.
- 5.5 Slowly open the 1/4 turn diver supply outlet valve (2).
- 5.6 Confirm with the diver that an adequate air supply is being received at the mask/helmet.



THIS PAGE IS LEFT BLANK INTENTIONALLY





## 6.0 OPERATION

(Refer to drawing PP032109)

- 6.1 The panel works automatically but the operator should continuously monitor the H.P. / L.P. air supply and the L.P. supply to the diver (s).
- 6.2 When the diver is descending and ascending, the control panel operator may have to adjust the H.P. / L.P. regulator (1) depending on the mask/helmet configuration.
- 6.3 Under conditions of very low ambient temperature or when using inadequately filtered "wet" air, icing could occur within the H.P./L.P. regulator. This could be indicated by fluctuating or falling low pressure as shown on the LP gauge (5). If any signs of icing are noticed diving should be terminated immediately.



THIS PAGE IS LEFT BLANK INTENTIONALLY



## 7.0 PNEUMO OPERATION

(Refer to drawings PP0032102 & PP032109)

- 7.1 The divers' depths can be read from the pneumo gauges (13).
- 7.2 Turn on the pneumo valve (6) to supply air to the pneumo hose in the umbilical and allow the air to flow for enough time to ensure it is bubbling out of the open, diver end. (Usually confirmed by the diver via the comms).
- 7.3 When the air has bubbled out of the hose end, close off the supply valve (6) and read the hydrostatic pressure (shown as diver depth) on the pneumo gauge (13).
- 7.4 The depth must be checked periodically using the above method, particularly if the diver is changing depth whilst working. When his work is completed and the diver is returning to the surface, the gauge will automatically read his decreasing depth without the operator supplying more air to the pneumo hose.



THIS PAGE IS LEFT BLANK INTENTIONALLY



## 8.0 CYLINDER CHANGE OVER

(Refer to drawing PP032109)

- 8.1 Slowly turn on the reserve air supply via the H.P. inlet valve (7). Confirm there is an increase in pressure on the H.P. gauge (4).
- 8.2 Turn off the original air supply at the H.P. inlet valve (3).
- 8.3 Purge the H.P. hose to the cylinder to be removed. Disconnect the cylinder and replace it with a charged H.P. air cylinder.
- 8.4 Slowly turn on the new air cylinder.

**N.B.** Items 3 and 7 are identical and serve the same purpose. They are separately identified here only to illustrate the cylinder changing procedure.



THIS PAGE IS LEFT BLANK INTENTIONALLY



## 9.0 AUXILIARY LOW PRESSURE INLET

(Refer to drawing PP032109)

9.1 The panel has the facility for an auxiliary low pressure inlet. This low pressure air supply must not exceed 15 Bar. To use, connect the supply hose to the L.P. inlet and direct the supply to the appropriate diver using one of the red-handled auxiliary valves (8).

**N.B.** It is not advisable to use the L.P. supply for both divers at once as the deeper diver could experience a shortage of gas.



THIS PAGE IS LEFT BLANK INTENTIONALLY





## 10.0 LOW H.P. WARNING

(Refer to drawing PP032109)

- 10.1 The system comprises a battery pack (9), pressure switch, warning On/Off switch (10), red warning LED (11) and a high frequency buzzer (12). During normal operation, the On/Off switch (10) must be in the On position. The pressure switch is set to operate when the H.P. supply pressure falls below 50 Bar. When this occurs, the pressure switch illuminates the warning LED (11) and the buzzer (12) sounds continuously. The panel operator will establish which H.P. supply is low by finding the illuminated LED (11). The buzzer (12) may then be cancelled by switching the warning switch (10) Off while supply cylinders are changed over. It is important that the warning switch (10) is returned to the On position after completion of the cylinder change.



THIS PAGE IS LEFT BLANK INTENTIONALLY



## 11.0 MAINTENANCE

(Refer to drawing PP032109)

- 11.1 Very little maintenance is required and with the exception of the H.P. inlet valves (3 & 7) all components are factory assembled with no user serviceable parts.
- 11.2 Periodically inspect the panel for damage or signs of wear.
- 11.3 Check for air leaks by listening or by pressurising the panel, closing the valves and observing any pressure drop on the gauges. If a leak is suspected, remove the panel from its case and test for the leak with a liquid soap and water solution. Tighten any pipe connections only with the panel **de-pressurised**.
- 11.4 **General Instructions for the Removal of any Component**

Depressurise the system. Remove panel from case. Undo nut unions and remove the relevant piping. Remove the component. Repair or replace component. Remake all threaded joints using Locite 542 Hydraulic Seal or equivalent. Ensure that all mating surfaces and olives are clean. Do not over tighten the nut unions. Test for leaks. Return panel to case.



**11.5 H.P. Panel Valve.** Refer to following parts list and drawing **U1011**.

These can be serviced in situ.. Remove rubber handle by releasing the retaining nut. Unscrew the spindle nut and retract the spindle complete. Remove and inspect the valve seat. If it is undamaged, refit, If damaged, renew. Clean all items with a high quality industrial wiper. Re-assemble the valve, fitting a new Teflon spindle seal, O Ring and Copper Washer. Lubricate with light a smear of Molybdenum-Disulphide grease or any acceptable breathing air quality grease (e.g. Vaseline).

**H.P. valve recommended spares (Service kit DD051201)**

<u>Part Number</u>	<u>Description</u>	<u>Qty.</u>
DD051311	Handle retaining nut	1
DD051310	Spring	1
DD051322	Rubber handle	1
DD051309	Nylon washer	1
DD051323	Spindle nut	1
DD051307	Teflon spindle seal	1
DD051308	O Ring	1
DD051306	Spindle	1
DD051305	Valve seat assembly	1
DD051312	Copper washer	1
DD310302	Panel mounting nut	2
DD310307	Stainless steel washer	1
DD310301	Valve body	1

**11.6 H.P. Non-Return Valve.**

(Refer to drawing PP032004)

Test the HP non-return valves (19) by pressurising the panel then disconnecting one H.P. hose at a time and opening the corresponding valve checking for air loss from the inlet connection. If there is any air escaping, the faulty non-return valve should be replaced.



### 11.7 H.P. Regulator

(Refer to drawing PP032109)

Servicing must be carried out by an approved engineer, trained by the manufacturer in the correct maintenance of the regulator (1). If no local approved engineer is available, the units must be returned to **DIVEX** for service.

The only permissible routine service is to clean the filter, located between the regulator and the H.P. inlet.

Remove the panel from the case. Locate and remove the filter. Unscrew the end pieces and remove the filter element. Clean and replace all items in reverse order.

Ensure spill valve exhaust port is kept open.

### 11.8 Gauges

These should be inspected on a regular basis to check for fluid loss. Also ensure that the pointer returns to zero when the pressure is released. The gauges should be calibrated in accordance with national regulations.

Damaged gauges should be replaced.

**When replacing any components ensure that the previously noted procedures regarding cleanliness, sealants and re-assembly of nut unions are adhered to.**



THIS PAGE IS LEFT BLANK INTENTIONALLY



## **12.0 MAINTENANCE SCHEDULE - 6 MONTHLY**

- 12.1 Inspect lid and outer casing for damage. Check hinges and catches for correct operation.
- 12.2 Remove H.P. Panel Valve. disassemble as described in Section 11.5 Inspect. Wipe clean with a high quality industrial wiper, lubricate with approved grease and re-assemble.
- 12.3 Check for free movement of 90° Diver Outlet Valves, Pneumo Valves and L.P. Isolator Valve. Section 11 for replacement.
- 12.4 Test H.P. Regulator by pressurising the system until the safety relief valve "blows" at 290 PSI. . When reducing pressure (turning valve anti-clockwise) listen for the release of air through the Spill Valve.
- 12.5 Inspect all gauges for leakage of fluid and check that the needle returns to zero when the system is depressurized.
- 12.6 Pressurise complete system and listen for leaks.



THIS PAGE IS LEFT BLANK INTENTIONALLY





## 13.0 DIVER COMMUNICATIONS

### INDEX

WARNING

13.1 INTRODUCTION

13.2 FRONT PANEL DESCRIPTION

13.3 SYSTEM CONNECTIONS

13.4 SYSTEM CHECK-OUT

13.5 NORMAL OPERATION

13.6 FAULT FINDING

13.7 SPECIFICATIONS

13.8 PARTS LIST

13.9 ACCESSORIES



## **WARNING**

**The operation of this product may be adversely affected if used in the presence of high electro-magnetic interference e.g. in close proximity to radio transmitters, or in an industrial environment where inductive electrical loads are being switched.**



## 13.1 INTRODUCTION

- 13.1.1 The Divers Air Telephone Model D8802 is a surface terminal for a communication system designed for use between a surface tender and two divers. The system allows for individual communication with each diver, communication with both divers at once and also allows the divers to talk to each other. Facilities are provided to connect the system for four wire open channel operation.
- 13.1.2 In normal two-wire operation of the system, control is entirely from the surface terminal which is biased to normally receive messages from the divers. Only when the surface operator transmits is the receiver speaker inoperative for reception, if however, the system is connected for four wire operation, with the surface operator wearing a headset and microphone, then two-way communication is possible on open channel.
- 13.1.3 The Model D8802 is housed in an aluminium panel fitted within the lid of the transit case.



THIS PAGE IS LEFT BLANK INTENTIONALLY

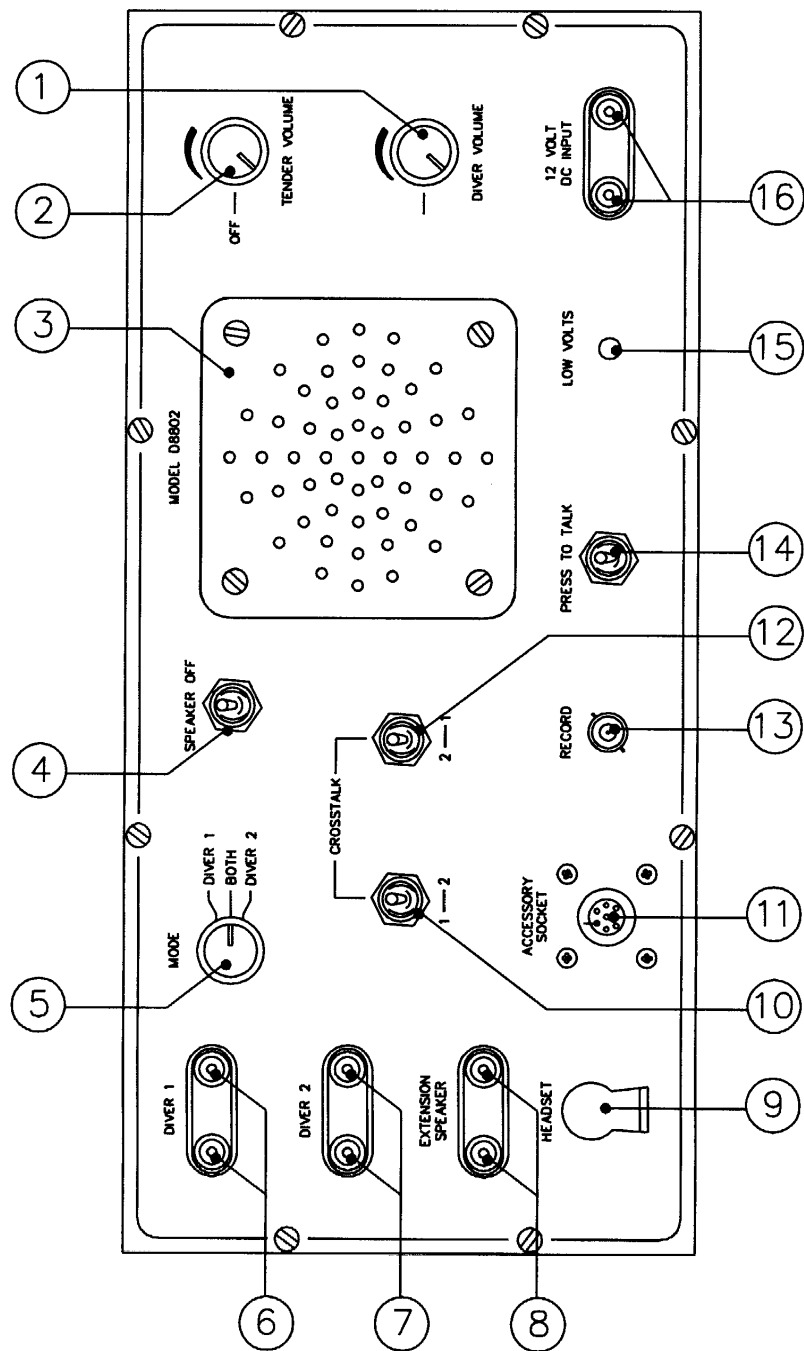
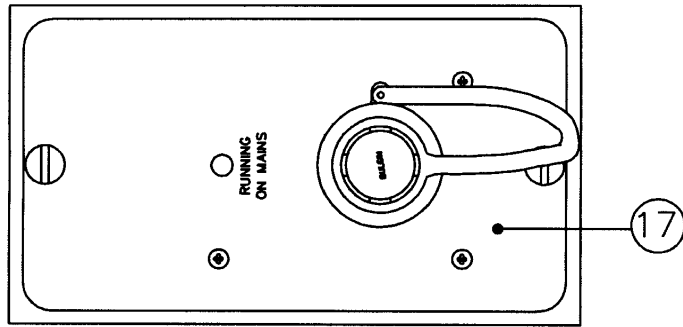



### 13.2 FRONT PANEL DESCRIPTION

1	DIVER VOLUME	Sets the level at which the diver receives the tender's communication.
2	OFF/TENDER VOLUME CONTROL	Switches the system on or off and sets the level at which the tender receives the diver's communication.
3	SPEAKER/MICROPHONE	Item 3 is normally operated as a speaker but is used as a microphone when the 'Press To Talk' switch is activated.
4	SPEAKER ON/OFF SWITCH	Switches the speaker/microphone off when a headset or remote station are used.
5	MODE SWITCH	The mode switch is used to select the diver that the tender wants to communicate with. By selecting the 'both' position, the tender can monitor and communicate with both divers.
6	DIVER 1	Input/Output connections for diver 1 communication cables.
7	DIVER 2	Input/Output connections for diver 2 communication cables.
8	EXTENSION SPEAKER	Extension speaker input/output terminals. When 'Press To Talk' switch is operated, the extension speaker operates as a microphone.
9	HEAD SET SOCKET	Stereo jack socket for connection of a headset and or microphone.
10	CROSS TALK 1 TO 2	Activation of this switch enables diver 1 to talk to diver 2.
11	ACCESSORY SOCKET	Used for a range of accessories and remote options.
12	CROSS TALK 2 TO 1	Activation of this switch enables diver 2 to talk to diver 1.



- |    |                    |  |
|----|--------------------|--|
| 13 | RECORD             | Output connection for connecting a tape recorder.  |
| 14 | PRESS TO TALK      | Is a biased switch, when enabled, allows the tender to talk to the diver or divers selected on the mode switch.                      |
| 15 | LOW VOLTS          | An LED indicator which flashes when the battery voltage level falls below a preset voltage level.                                    |
| 16 | 12 VOLT d.c. INPUT | Positive and negative terminals for connection of an external d.c. power supply, this input is protected against reverse connection. |
| 17 | MAINS MODULE       | AC adapter and battery charger.  |



## 13.3 SYSTEM CONNECTIONS

### 13.3.1 POWER SUPPLY

The comms system is supplied with an internal rechargeable battery. A mains module is provided which allows an AC supply of either 100V-140V or 200V-280V 50Hz or 60Hz to be used. This module also acts as a charger for the internal battery. A 12V DC supply can also be used via the terminals in front of the unit.

### 13.3.2 TWO WIRE OPERATION

With this method of connection, the Model D8802 acts as a common terminal box and controls the routing of communications from the divers and the surface operator. Surface reception may be on the built-in speaker of the Model D8802 or on the extension speaker which also acts as a microphone in the transmit mode. A jack socket is provided for the connection of a headset and boom microphone, an independent speaker on/off switch is also provided to enable the operator to use a headset and microphone and still leave the panel speaker operational, if he so requires. A further option is available via the accessory socket (refer to Section 9).

The two wires from each diver's microphone/earphone are connected in parallel in the divers' masks, then connected to the respective input terminals as shown in the external wiring diagram overleaf, i.e. diver 1 wires to terminals marked DIVER 1. It is assumed that the system is now connected and ready for use. With the unit switched on and the speaker on/off switch in the 'on' position, the unit continuously monitors the divers' speech according to the position of the mode switch - either diver 1, 2 or BOTH. Reception level volume at the surface terminal is controlled by the TENDER VOLUME control.

The surface operator may speak to the diver or divers by pressing the spring loaded 'press to talk' switch or via remote 'Press To Talk' via the accessory socket (refer to Section 9). Reception volume for the diver is controlled by the diver volume control on the front panel of the surface unit. It should always be remembered that in two wire operation, when transmission from the surface unit is taking place, it is not possible to receive communications from the divers. Transmission should therefore be kept to a minimum, to keep the channel open for possible emergency calls.





### 13.3.3 CROSS-TALK

Diver to diver communications are possible via the surface terminal. The tender operating the surface terminal controls the speech routing, and permits the conversation by moving the 'cross-talk' switch 1 to 2 or 2 to 1, as required. When diver to diver communication is in progress, it is monitored on the surface unit by the tender. Note for cross-talk operation - the mode switch should be in the 'both' position.

### 13.3.4 MICROPHONE AND SPEAKER REQUIREMENTS

For two wire operation, where the divers' microphone is used as a speaker also, then a low impedance transducer is required (4 to 600 ohms).

### 13.3.5 ROUND ROBIN CONNECTION

This method requires a separate headset and microphone at every station, including the surface terminal. For every set in the system the microphones are wired to the DIVER 1 terminals of the Model 8802 surface unit. ALL the headset earphones are connected to the EXTENSION SPEAKER terminals. The tender volume control should be turned to the 'ON' position, but will have no effect on the volume levels. The only volume control that is effective in this mode of operation is the divers' volume control, also the various 'Press To Talk' switches are inoperative.

External Wiring Diagram

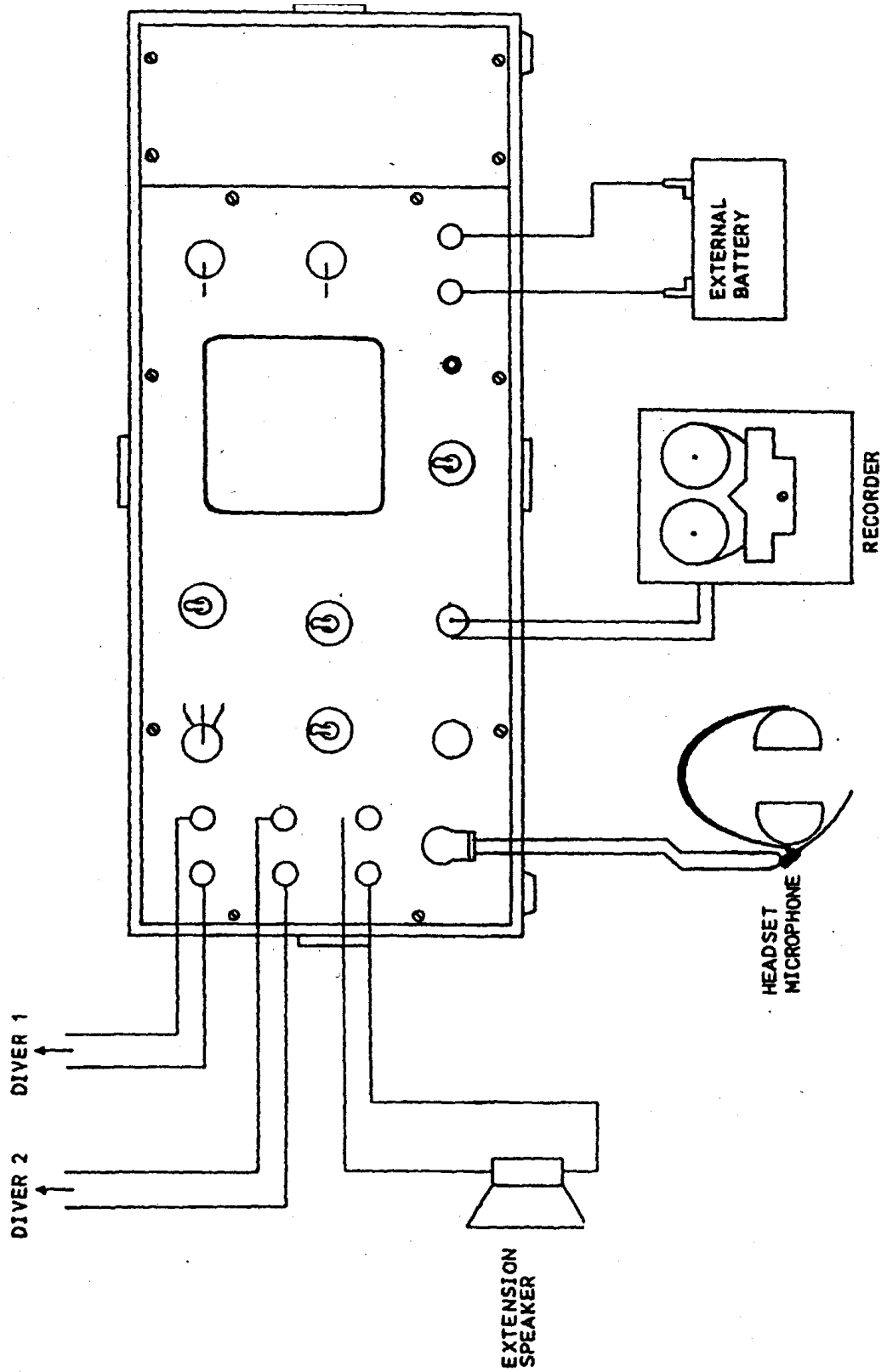

# Internal Wiring Diagram

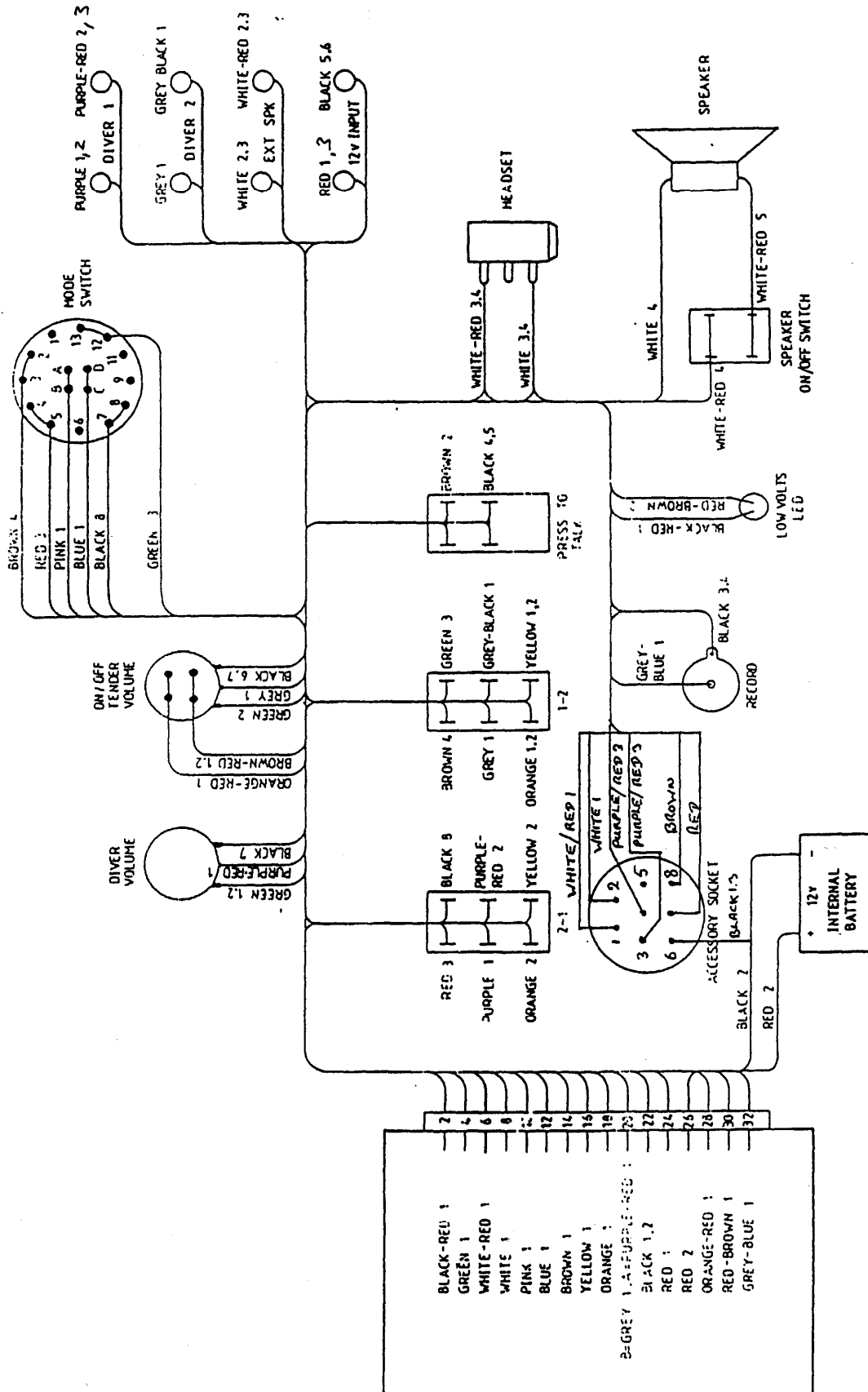



### 13.4 SYSTEM PRE-DIVE CHECK

Before each dive, the system should be checked with the diver on the surface using the following procedure.

1. Check the end connection of the cables for signs of fraying or other damage and rectify any problems before the dive commences.
2. Check that the wires are connected as described in the relevant section.
3. Check the following switch positions on the Model D8802.

TENDER volume control turned '**ON**'.  
SPEAKER switch to the '**ON**' position.  
MODE switch set to '**BOTH**'.

4. Have the diver stand some distance away from the surface terminal and (preferably to the rear of the unit, to avoid the possibility of feedback) - speak into the microphone. Adjust the tender volume control so that a satisfactory volume level is obtained on the surface unit's loudspeaker. If four wire operation is used, then reception will be on the surface operator's headset, and the DIVERS volume control will be used to set the reception level.
5. Operate the 'Press To Talk' switch and talk into the loudspeaker (the operator should be in a comfortable position and speaking in a normal voice level) - adjust the DIVER volume control until the receive level in the divers' mask is satisfactory. If feedback noise is obtained as the diver speaks, either turn down any one of the volume controls or switch the speaker switch to the '**OFF**' position. Having cleared the feedback noise, get the diver to move further away from the surface station (or use a much reduced volume setting) and repeat the test.



### 13.5 NORMAL OPERATION

Having completed the surface checks, communication should now proceed smoothly during the dive. If two divers are operating together in two wire connection, it will be necessary to operate the crosstalk switches on the surface terminal to enable the divers to talk to each other. While this conversation is in progress it is continuously monitored by the surface tender. Should it be required, all communications can be recorded by connection of a tape recorder to the front panel socket marked **RECORD**. Facilities for a headset and microphone with remote 'press to talk' are provided by connection to the socket marked **ACCESSORY** (further options provided by this output - refer to section 13.10).

If the **LOW VOLTS** indicator starts to flash during the dive, there is no immediate cause for alarm as typically there are four or more hours of normal operation before the batteries have to be changed. However both batteries should be changed at the first opportunity. Never start a dive with the **LOW VOLTS** light flashing.



## 13.6 FAULT FINDING

In the event of a malfunction of the Model D8802, the following checks should be carried out:-

13.6.1 Switch the **POWER** on for one or two seconds and then switch it off again. The **LOW VOLT** light should flash for a brief period as the power is switched off. If not, then the battery is either unserviceable or the battery connections are not made properly. If the led flashes as above, then continue.

13.6.2 Connect a diver's speaker/microphone to the **DIVER 1** terminals and set the **MODE** switch to **DIVER 1**. Check that there is an audio output at the surface terminal loudspeaker as you speak into the diver's microphone (adjust the **TENDER VOLUME** or move the microphone further away from the surface terminal if there is feedback).

If this is satisfactory, push the **PRESS TO TALK** switch, speak into the surface terminal loudspeaker and check that there is reception at the diver's microphone/speaker. If there is an audio signal in only one of the two cases, the **PRESS TO TALK** switch is probably defective.

13.6.3 To check the operation of the **PRESS TO TALK** circuit, with **POWER 'ON'**, short circuit pin 2 & 3 on the accessory socket. The relay on the circuit should be heard to click as the connection is made and broken, if not, the relay is defective and the printed circuit board of the Model D8802R must be changed. If the unit this time works properly, the **PRESS TO TALK** switch is defective and should be changed. If there is still no audio signal and the relay is confirmed to be operating, then continue:

13.6.4 Connect an external loudspeaker to the **EXTN SPEAKER** terminals and repeat the test in item 7.2 above. If the unit now functions properly, the built-in speaker of the surface terminal is defective. Check the wiring to the speaker and if this is in good order, replace the speaker.

13.6.5 To check the **TENDER VOLUME** control, connect an ohmmeter across the centre terminal and one of the others. Check that the resistance increases and decreases smoothly by about 10K ohm as the volume control is moved. If not, then the control is defective.

13.6.6 Check the **DIVER VOLUME** control in the same way.



- 13.6.7 Check the operation of the **MODE** selector switch and the **CROSS TALK** switches:-
- a) Inset the probes of an ohmmeter in the right hand terminals of the **DIVER 1** and **DIVER 2** connection. Set **MODE** switch to **'BOTH'** - the ohmmeter should indicate a closed circuit.
  - b) Set **MODE** switch to **'1'** or **'2'** - the ohmmeter should indicate an open circuit.
  - c) Set **MODE** to **'BOTH'** again. Press **CROSS TALK 2** to **1** - the ohmmeter should indicate open circuit.
- 13.6.8 Trouble shooting the printed circuit board in the field is not recommended unless an experienced technician is on hand, in which case the wiring diagram will assist. Otherwise, return the circuit board or the complete instrument to the manufacturer for repair.



### 13.7 SPECIFICATIONS

- Mains power pack
  - Two ranges set by internal selector on P.C.B.
  - Input voltage 110V setting (80 to 140)
  - Input voltage 220V setting (160 to 280)
- Mains frequency
  - 50/60 Hz
- Audio power output
  - 7 watts R.M.S. (into 4 ohms)
- Frequency Response
  - 300 Hz to 12 kHz
- Input Impedance
  - 4 to 600 ohms
- Headset Impedance
  - 4 to 600 ohms
- Extension Speaker
  - 4 to 600 ohms
- Diver input/output
  - Overload protected, short circuit protected
- Tender input-output
  - Overload protected, short circuit protected
- Extension Speaker
  - Overload protected, short circuit protected
- Tape recorder output
  - 75 millivolts into 1K
- Low voltage indication
  - Flashes at 10.2 volts





## 13.8 PARTS LIST

Items marked with \* are recommended spares.

<u>Description</u>	<u>Quantity</u>
Front Panel	1
Battery Compartment Door	1
Speaker Fixing Screws	4
Front Panel Fixing Screws	8
Battery Door Screws	2
Rubber Boots for Switches	5 *
Volume Control Knob	2
Mode Selector Knob	1
Divers Line Terminal Sockets (red)	4 *
Extension Speaker Terminals (blue)	2
External 12V d.c. supply terminal (red)	1
External 12V d.c. supply terminal (black)	1
Speaker	1
Diver Volume Potentiometer	1 *
Tender Volume Potentiometer with Switch	1 *
Press to Talk	1 *
Cross Talk Switches	2
Speaker On/Off Switch	1 *
Mode Switch	1 *
Accessory Socket	1
'Tape Recorder' Socket	1
'Low Voltage' LED	1
Printed Circuit Board Assembly	1 *
Battery Connection Strip	1

## **13.9 ACCESSORIES**

Headset with boom noise cancelling boom microphone.

Remote Press to Talk switch.

Remote Press to Talk switch with headset.

Voice activated switch.

Remote extension speaker with Press to Talk facility.

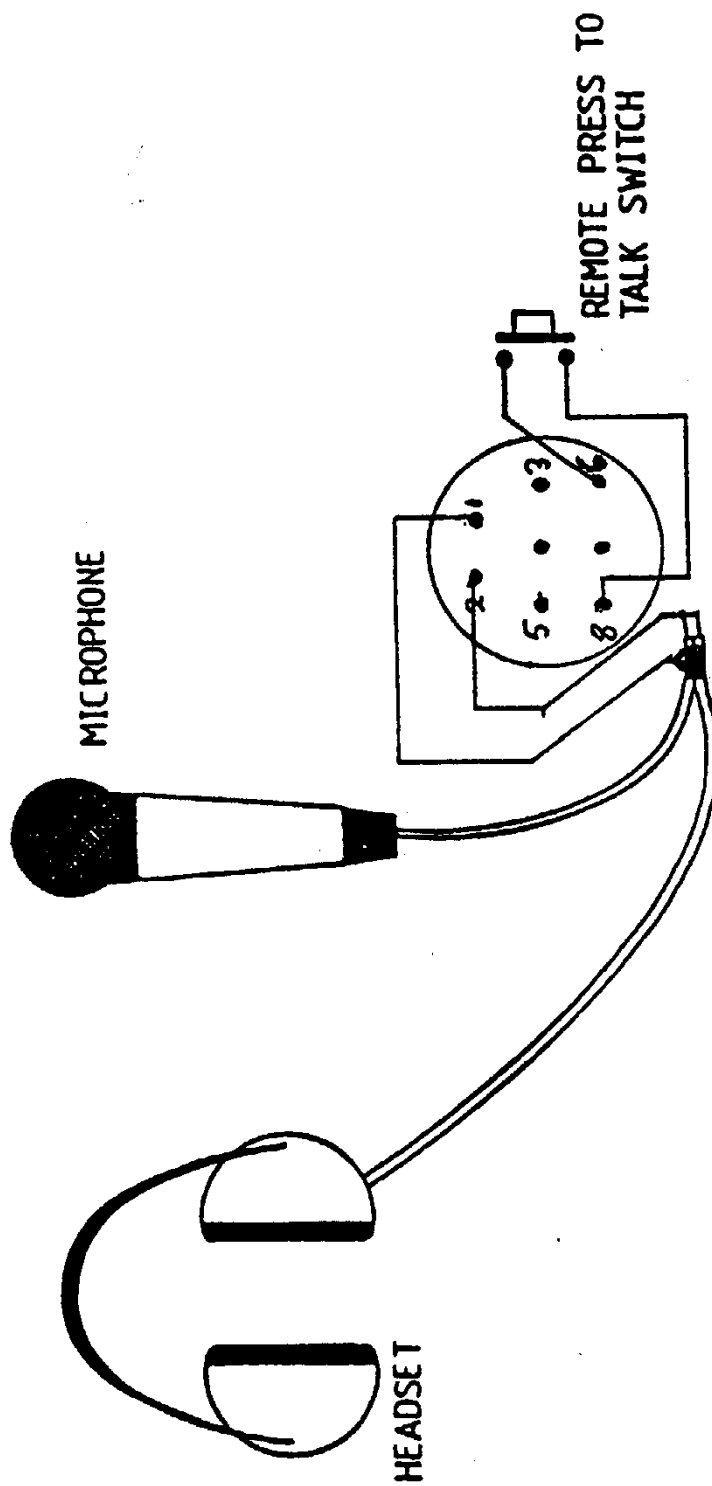



THIS PAGE IS LEFT BLANK INTENTIONALLY

# 14.0 TAPE RECORDER

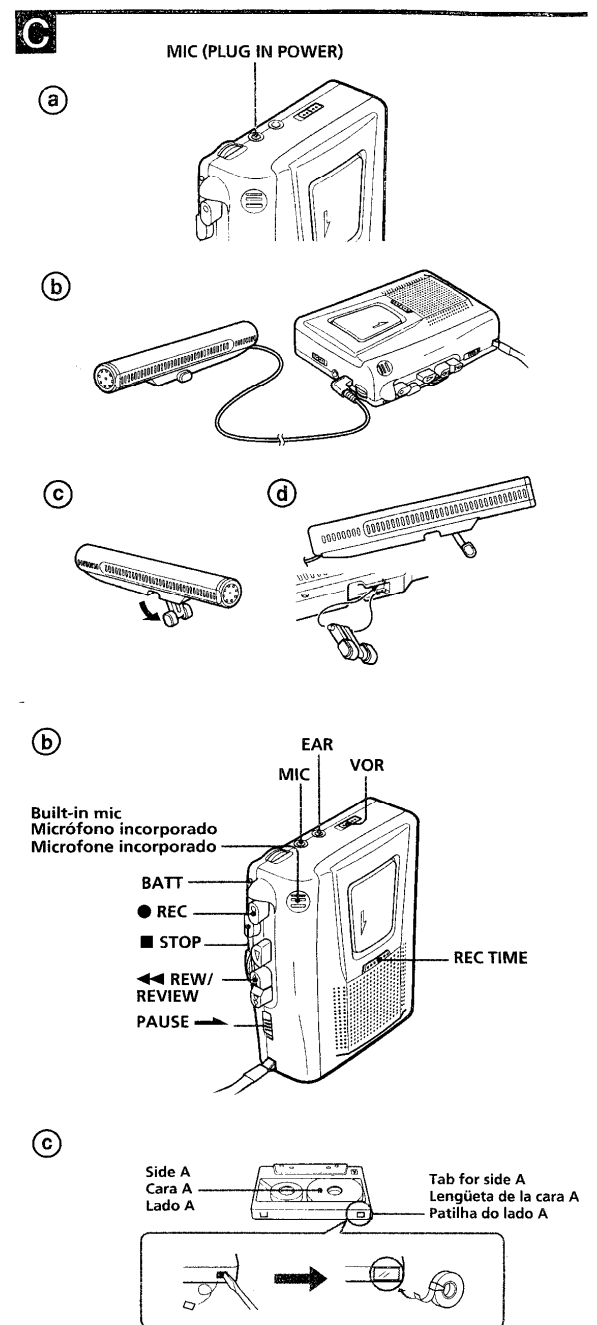
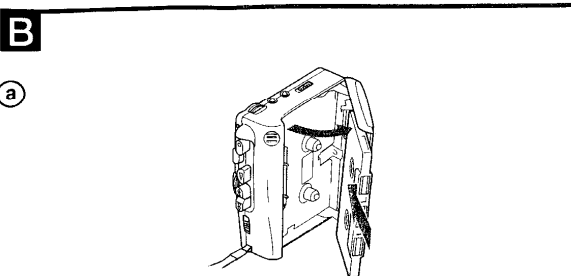
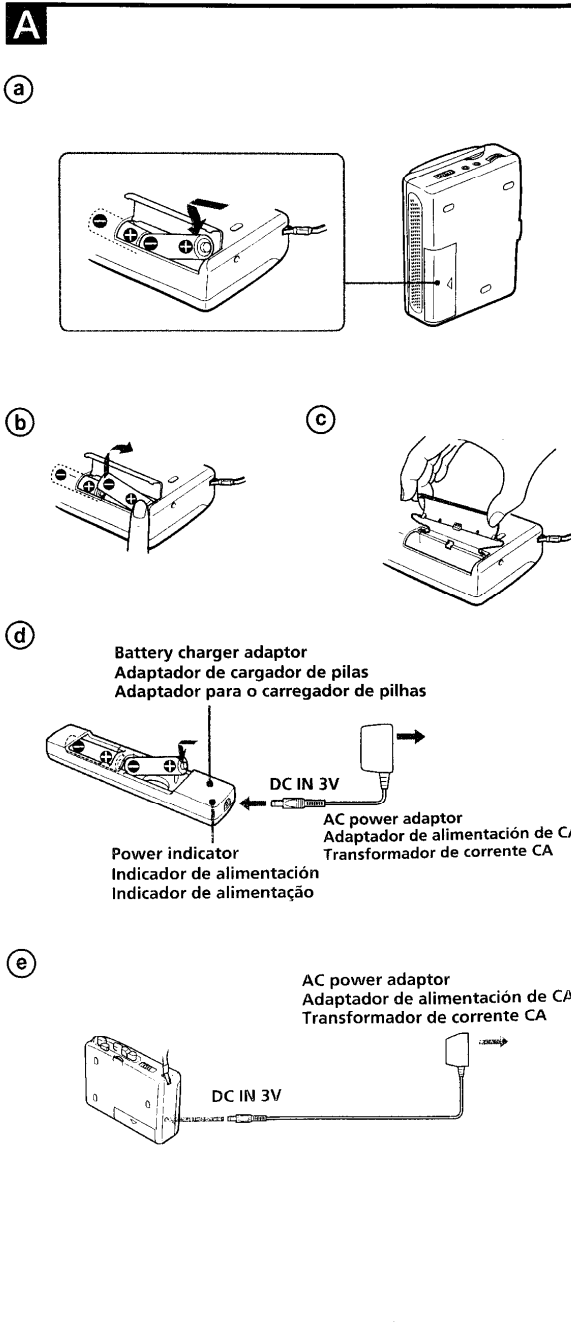

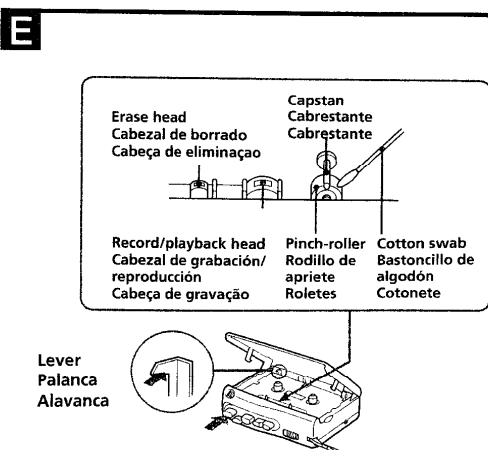
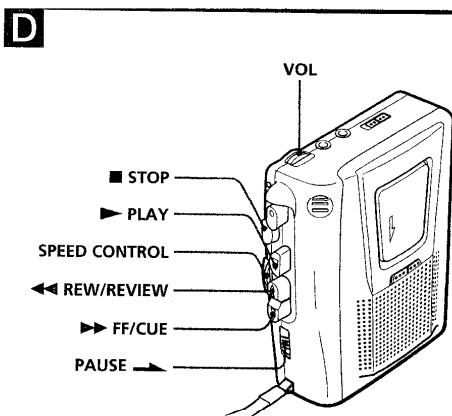

## Welcome !

Thank you for purchasing the Sony Cassette-Corder.

This Cassette-Corder is equipped with a REC TIME switch that lets you record double the normal length on any cassette.

### Note

Tapes recorded with the RFC TIME (2.4 cm/s) switch in the DOUBLE position cannot be played properly by a tape recorder without the REC TIME switch function.

## Supplied accessories

The instructions in this manual are for 4 models. The TCM-20DV is the model used for illustration purposes.

TCM	20DV	22DV	21DV	20DV
AC power adaptor (1)	—	○	—	—
Battery charger adaptor (1)	—	○	—	—
Rechargeable batteries (2) (NC-AA, 1.2V, 700mAh, Ni-Cd)	—	○	—	—
Cassette tape C-90 (1)	—	—	○	—
Battery LR6 (2)	—	—	○	—
Monaural microphone (1)	—	—	○	—
Super-directional microphone (1)	○	—	—	—
Carrying pouch (1)	—	—	○	—
Hand strap (1) (attached to the unit)	○	○	○	○

## Getting Started

### Preparing a Power Source

Choose one of the following power sources.

#### Dry Batteries (see Fig. A-③)

Make sure that nothing is connected to the DC IN 3V jack.

- 1 Open the battery compartment lid.
- 2 Insert two size R6 (AA) batteries (TCM-21DV: supplied) with correct polarity and close the lid.

#### Notes

- Do not charge a dry battery.
- Do not use a new battery with an old one.
- Do not use different types of batteries.
- When you do not use the unit for a long time, remove the batteries to avoid any damage caused by battery leakage and subsequent corrosion.
- Dry batteries will not be expended when another power source is connected.

#### To take out the batteries (see Fig. A-④)

#### To attach the battery compartment lid if it is accidentally detached (see Fig. A-⑤)

#### Rechargeable Batteries (see Fig. A-⑥) (supplied to TCM-22DV only)

Before using the rechargeable batteries, charge them with the supplied battery charger adaptor and AC power adaptor.

- 1 Insert the rechargeable batteries (NC-AA) into the battery charger adaptor with correct polarity.
- 2 Connect the AC power adaptor (supplied to TCM-22DV) to the DC IN 3V jack of the battery charger adaptor and to the wall outlet. The power indicator lights up.

- 3 Unplug the AC power adaptor from the wall outlet and from the battery charger adaptor after about 8 hours.

#### Notes

- The power indicator lights in green as long as the AC power adaptor is plugged to the wall outlet and the DC IN 3V jack, even when the charging has not been done.
- Use only the supplied or recommended AC power adaptor, battery charger adaptor and rechargeable batteries.
- The rechargeable batteries can be charged approximately 500 times.
- Do not leave the battery charger adaptor plugged in for more than 20 hours. Overcharging may damage the rechargeable batteries.

#### When to replace the batteries (see Fig. B-①)

Replace the batteries with new ones or charge the batteries (supplied to TCM-22DV only) when the BATT lamp dims.

#### Notes

- After the batteries have been used for a while, the BATT lamp may flicker with the playback sound when you turn up the volume; however, this does not mean that you need to replace the batteries.
- The unit will play back normally for a while even after the BATT lamp dims. However, replace the batteries as soon as you can. If you do not, subsequent recording will not be done correctly.

#### Battery life (Approx. hours) (EIAJ\*)

	Playback	Recording
Sony alkaline LR6 (SG)	11	11
Sony R6P (SR)	3	3
Sony rechargeable battery (NC-AA) fully charged (TCM-22DV only)	3	3

\* Measured value by the standard of EIAJ (Electronic Industries Association of Japan). (Using a Sony HF series cassette tape and playing back with speakers)

#### Note

The battery life may shorten depending on the operation of the unit.

For maximum performance we recommend that you use alkaline batteries.

#### House Current (see Fig. A-②)

Connect the AC power adaptor to DC IN 3V and to a wall outlet. The AC power adaptor is supplied only with the TCM-22DV. For other models, use the AC-E30HG AC power adaptor (not supplied). Do not use any other AC power adaptor.



#### Note

Specifications for AC-E30HG vary for each area. Check your local voltage and the shape of the plug before purchasing.

#### Operating the Unit

#### Recording (see Fig. B-①, ②)

You can record right away with the built-in microphone. Make sure that nothing is connected to the MIC jack.

- 1 Insert a normal (TYPE I) tape with the side to start facing the cassette holder.

- 2** Set REC TIME to the desired mode.  
 NORMAL (4.8cm/s): for optimum sound. Recommended for normal recordings.  
 DOUBLE (2.4cm/s): for double recording time (for example, 120 minutes using both sides of a 60-minute cassette). Suitable for recording conferences, dictations, etc. Not recommended to record music.

- 3** Set VOR to: H or L to start and pause recording automatically to the sound.  
 H (high) to record at meetings or in a quiet and/or spacious place.  
 L (low) to record for dictation or in a noisy place.  
 Set VOR to OFF to start and stop recording manually.

**Note**  
 When the sound to be recorded is not loud enough, set the VOR switch to OFF, or the unit may not start recording.

- 4** Press ● REC.  
 ► PLAY is pressed simultaneously and recording starts.

At the end of the tape, recording stops and the unit turns off automatically.

To	Press or slide
Stop recording	■ STOP
Pause recording	PAUSE ► in the direction of the arrow To release pause recording, release PAUSE ►*.
Review the portion just recorded	Press and hold ◀◀ REW/REVIEW during recording. Release the button at the point to start.
Take out a cassette	Press ■ STOP and open the cassette compartment lid by hand.

\* PAUSE ► will also be automatically released when ■ STOP is pressed (stop-pause-release function).

#### To monitor the sound

Connect an earphone (not supplied) firmly to the EAR jack.

#### Notes

- Do not use a High-position (TYPE II) or metal (TYPE IV) tape, otherwise the sound may be distorted when you play back the tape, or the previous recording may not be erased completely.
- The SPEED CONTROL switch works in the playback mode only. Recording will be made independent of this control.

#### Notes on VOR (Voice Operated Recording)

- When you use the VOR system in a noisy place, the unit will stay in the recording mode. If the sound is too soft, on the contrary, the unit will not start recording. Set VOR to H (high) or L (low) depending on the conditions to pick up necessary sound only.
- The VOR system depends on the environmental conditions. If you cannot get the desired results even though you adjust VOR to H or L, set VOR to OFF.

#### To prevent a tape from being accidentally recorded over (see Fig. B-C)

Break off and remove the cassette tabs. To reuse the tape for recording, cover the tab hole with adhesive tape.

## Recording from Various Sound Sources (see Fig. C)

### Recording with the supplied Microphone (see Fig. C-B) (Supplied to TCM-23DV only)

Connect the supplied "Super-directional microphone" (monaural) to the MIC jack and direct the microphone to the sound source.

#### Note

The supplied microphone will pick up noise if it is hand held while recording. Place the microphone on a flat surface.

#### To use the stand (see Fig. C-C)

#### If the stand gets detached (see Fig. C-D)

Attach the stand as shown.

### Recording with an External Microphone

Connect a microphone to the MIC jack. The raised bar near the MIC jack identifies as the jack for a microphone not an earphone. For TCM-21DV/23DV: Use the supplied microphone. For other models: Use a microphone of low impedance (less than 3 kilohms) such as ECM-T115 (not supplied). When using a plug-in-power system microphone, the power to the microphone is supplied from this unit.

#### Note

When recording with an external microphone, the VOR system may not work properly due to difference in sensitivity.

### Recording from Another Equipment

Connect another equipment to the MIC jack using the RK-G64HG connecting cord (not supplied).

## Playing a Tape (see Fig. D)

- Insert a cassette with the side to start playing facing the cassette holder.
- Set REC TIME to the same position as that used for recording.  
To playback commercially sold tapes, select NORMAL.
- Press ► PLAY and then adjust the volume. There is a raised dot beside VOL to show the direction to turn down volume.
- Adjust the tape playback speed. Set SPEED CONTROL to: SLOW (slow) to play back a tape slower.  
Center position to play back a tape at normal speed.  
FAST (fast) to play back a tape faster speed.

At the end of the tape, playback stops and the unit turns off automatically.

If you plug in headphones (not supplied) to the EAR jack, you will get monaural output from both left and right channels.

To	Press or slide
Stop playback/ stop fast forward or rewind	■ STOP
Pause playback	PAUSE ► in the direction of the arrow To release pause playback, release PAUSE ►*.
Search forward during playback (CUE)	Press and hold ►► FF/CUE and release it at the point you want
Search backward during playback (REVIEW)	Press and hold ◀◀ REW/REVIEW and release it at the point you want
Fast forward**	►► FF/CUE during stop
Rewind**	◀◀ REW/REVIEW during stop
Start recording during playback	● REC
Take out a cassette	Press ■ STOP and open the cassette compartment lid by hand.

\* PAUSE ► will also be automatically released when ■ STOP is pressed (stop-pause-release function).

\*\* If you leave the unit after the tape has been wound or rewound, the batteries will be consumed rapidly. Be sure to depress ■ STOP.

If the tape runs too fast or too slowly, check SPEED CONTROL.

## ► Additional Information

### Precautions

#### On power

- Operate the unit only on 3 V DC. For AC operation, use the AC power adaptor recommended for the unit. Do not use any other type. For battery operation, use two size R6 (AA) batteries.

- The nameplate indicating operating voltage, etc. is located on the bottom of the unit.

#### On the unit

- Do not leave the unit in a location near heat sources, or in a place subject to direct sunlight, excessive dust or mechanical shock.
- Should any solid object or liquid fall into the unit, remove the batteries or disconnect the AC power adaptor, and have the unit checked by qualified personnel before operating it any further.
- Keep personal credit cards using magnetic coding or spring-wound watches etc. away from the unit to prevent possible damage from the magnet used for the speaker.
- If the unit has not been used for a long time, set it in the playback mode to warm it up for a few minutes before inserting a tape.



THIS PAGE IS LEFT BLANK INTENTIONALLY





## 15.0 APPENDICES

Drawing:	PP032004	Fit-Out Schematic
	PP032102	Communications Panel Assembly
	PP032109	Diver Air Panel Assembly
	U1011	H.P. Control Valve spare parts

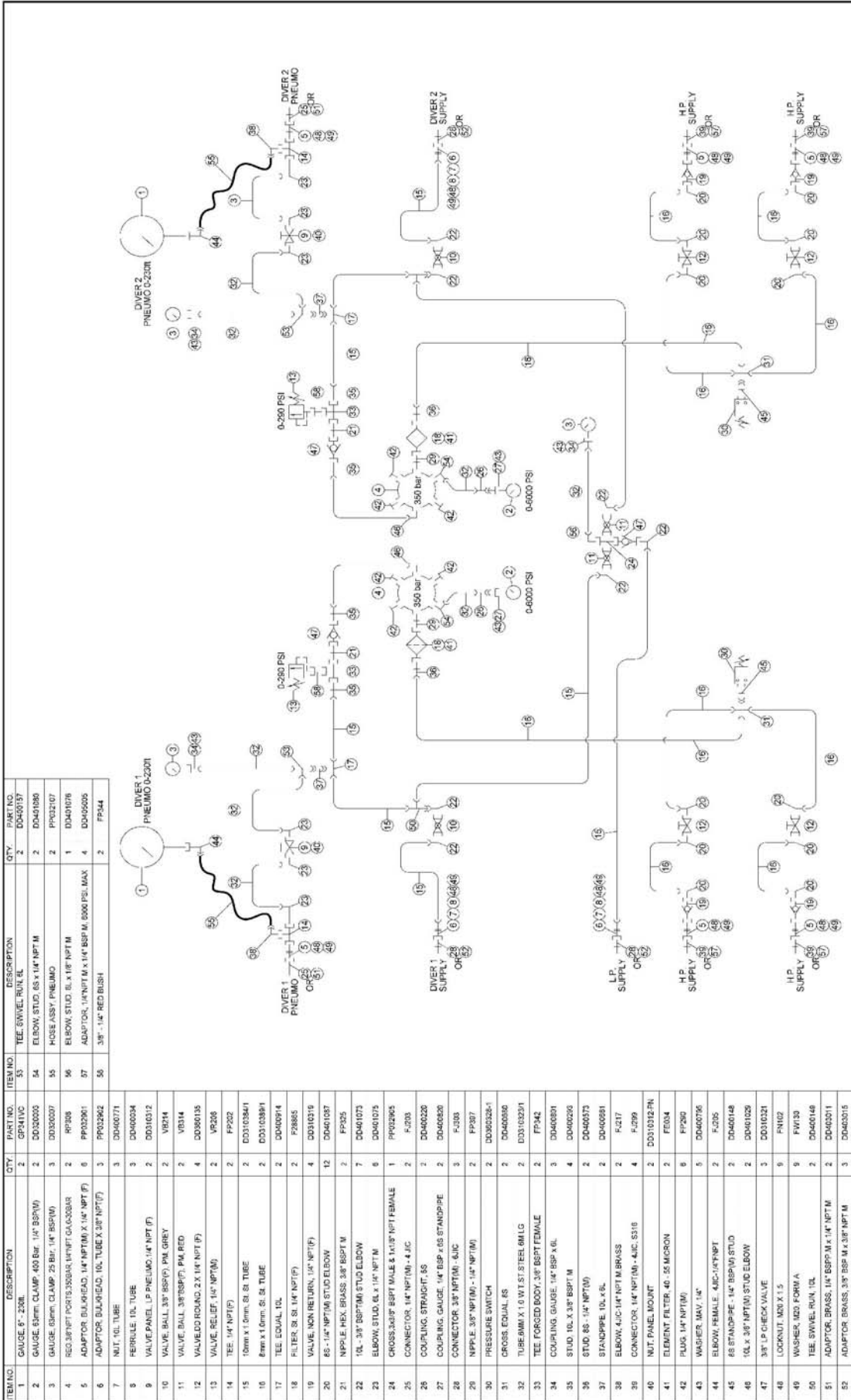

ITEM NO.	DESCRIPTION	QTY.	PART NO.	ITEM NO.	DESCRIPTION	QTY.	PART NO.
1	GAUGE, P., 250#	2	DP41VC	53	TEE, SWIVEL, RUL. EL.	2	DD40137
2	GAUGE, 0.8cm. CLAMP, 400 Bar, 1/4" BSP(M)	2	DD30000	54	ELBOW, STD., 65 x 1/4" NPT M	2	DD41886
3	GAUGE, 0.8cm. CLAMP, 25 Bar, 1/4" BSP(M)	2	DD30007	55	HOSE, ASSY, PNEUMO	1	PP02107
4	REC. 3/8" NPT PORT TO 3/32" BORE 1/4" NPT GA-00048	2	RP208	56	ELBOW, STD., 65 x 1/4" NPT M	1	DD40106
5	ADAPTOR, BULKHEAD, 1/4" NPT M x 1/4" BSP M, 8000 PSI, MAX	4	PP02361	57	ADAPTOR, 1/4" NPT M x 1/4" BSP M, 8000 PSI, MAX	4	DD40605
6	ADAPTOR, BULKHEAD, 1/2" NPT M x 3/8" NPT(F)	2	PP02942	58	3/8" x 1/4" RED BUSH	2	FP344
7	NUT, 1/2" TUBE	3	DD40071				
8	FERRULE 1/2" TUBE	3	DD40034				
9	VALVE, PANEL, LP PNEUMO, 1/4" NPT (F)	2	DD10102				
10	VALVE, BALL, 3/8" BSP(F), PH. GREY	2	VR214				
11	VALVE, BALL, 3/8" BSP(F), PH. RED	2	VR314				
12	VALVE, DODGSON, 2 X 1/4" NPT (F)	4	DD360135				
13	VALVE, RELIEF, 1/4" NPT(M)	2	VR208				
14	TEE, 1/4" NPT(F)	2	FP202				
15	10mm x 1.0mm, SI. ST. TUBE	2	DD3103841				
16	8mm x 1.0mm, SI. ST. TUBE	2	DD3103891				
17	TEE, EQUAL, 1/2"	2	DD400914				
18	FILTER, SI. 1/4" NPT(F)	2	FP2655				
19	VALVE, NON RETURN, 1/4" NPT(F)	4	DD101019				
20	65 - 1/4" NPT(M) STD. ELBOW	12	DD401087				
21	NPLE, HEX. BRASS, 3/8" BSP(T)	2	FP265				
22	10L - 3/8" BSP(T) STD. ELBOW	7	DD401073				
23	ELBOW, STD., 65 x 1/4" NPT M	6	DD401075				
24	CROSS, 3/8" BSP FEMALE & 1/4" NPT FEMALE	1	PP02265				
25	CONNECTOR, 1/4" NPT(M) - 4 JIC	2	F-103				
26	COUPLING, STRAIGHT, 5/8"	2	DD400220				
27	COUPLING, GAUGE, 1/4" BSP - 65 STANDPIPE	2	DD400680				
28	CONNECTOR, 3/8" NPT(M) - 4 JIC	3	F-103				
29	NPLE, 3/8" NPT(M) - 1/4" NPT(M)	2	FP267				
30	PRESSURE SWITCH	2	DD365326A-1				
31	CROSS, EQUAL, 65	2	DD400590				
32	TUBE, AMX 1.0 WT. ST. STEEL, 6 M.G.	2	DD3103291				
33	TEE, FORGED BODY, 3/8" BSP FEMALE	2	FP142				
34	COUPLING, GAUGE, 1/4" BSP x 6L	3	DD400591				
35	STD., 10L x 3/8" BSP(T)	4	DD400290				
36	STD., 65 - 1/4" NPT(M)	2	DD400173				
37	STANDPIPE, 10L x 6L	2	DD400591				
38	ELBOW, 4 JIC - 1/4" NPT M BRASS	2	F-217				
39	CONNECTOR, 1/4" NPT(M) - 4 JIC, S318	4	F-209				
40	NUT, PANEL, MOUNT	2	DD3103219L				
41	ELEMENT, FILTER, 40 - 25 MICRON	2	FE034				
42	PLUG, 1/4" NPT(M)	6	FP260				
43	WASHER, INV., 1/4"	5	DD400736				
44	ELBOW, FEMALE, 4 JIC - 1/4" NPT	2	F-205				
45	65 STANDPIPE - 1/4" BSP(M) STD.	2	DD400148				
46	10L x 3/8" NPT(M) STD. ELBOW	2	DD401029				
47	3/8" LP CHECK VALVE	3	DD101021				
48	LOCKNUT, M3 X 1.5	5	PN102				
49	WASHER, HD3 FORM A	9	FW130				
50	TEE, SWIVEL, RUL., 1/2"	2	DD400148				
51	ADAPTOR, BRASS, 1/4" BSP M x 1/4" NPT M	2	DD400311				
52	ADAPTOR, BRASS, 3/8" BSP M x 3/8" NPT M	3	DD400315				

**DIVEX**  
 UNLIMITED PRESSURE  
 ENGINES & PNEUMATIC  
 VESSEL  
 ASSEMBLY  
 UNITED KINGDOM  
 Tel: +44 (0)20 7616 7015  
 Fax: +44 (0)20 7616 7016  
 email: info@divexltd.com  
 www.divexltd.com

**REV** | **SCALE** | **DATE** | **AUTH.** | **BY**

1 | A1 | 14/12/2005 | PW |

**FIT-OUT SCHEMATIC  
 SURFACE CONTROL PANEL  
 COMPLETE WITH COMMS**

DRAWING NO. **PP32004S1** | REV. **R04**  
 PRODUCT PROJECT No. **HTU SYSTEM**

SEE PARTS LIST

**DO NOT SCALE DRAWING**

**THIRD ANGLE PROJECTION**

**DIMENSIONAL TOLERANCES**  
 FABRICATION  
 NO DECIMAL PLACES ±1.0 SIZE >0 <100 ±0.5  
 ONE DECIMAL PLACE ±0.2 SIZE >100 <500 ±1.5  
 TWO DECIMAL PLACE ±0.05 SIZE >500 ±3.0  
 ANGULAR TOLERANCE ±0.5°

**NOTES**  
 DIVEX OWNS THE COPYRIGHT OF THIS DOCUMENT AND ANY DESIGN RIGHT HEREIN. IT IS SUPPLIED IN CONFIDENCE AND MUST NOT BE USED FOR ANY PURPOSE OTHER THAN THAT FOR WHICH IT IS SUPPLIED AND MUST NOT BE REPRODUCED WITHOUT PERMISSION IN WRITING FROM THE OWNERS.

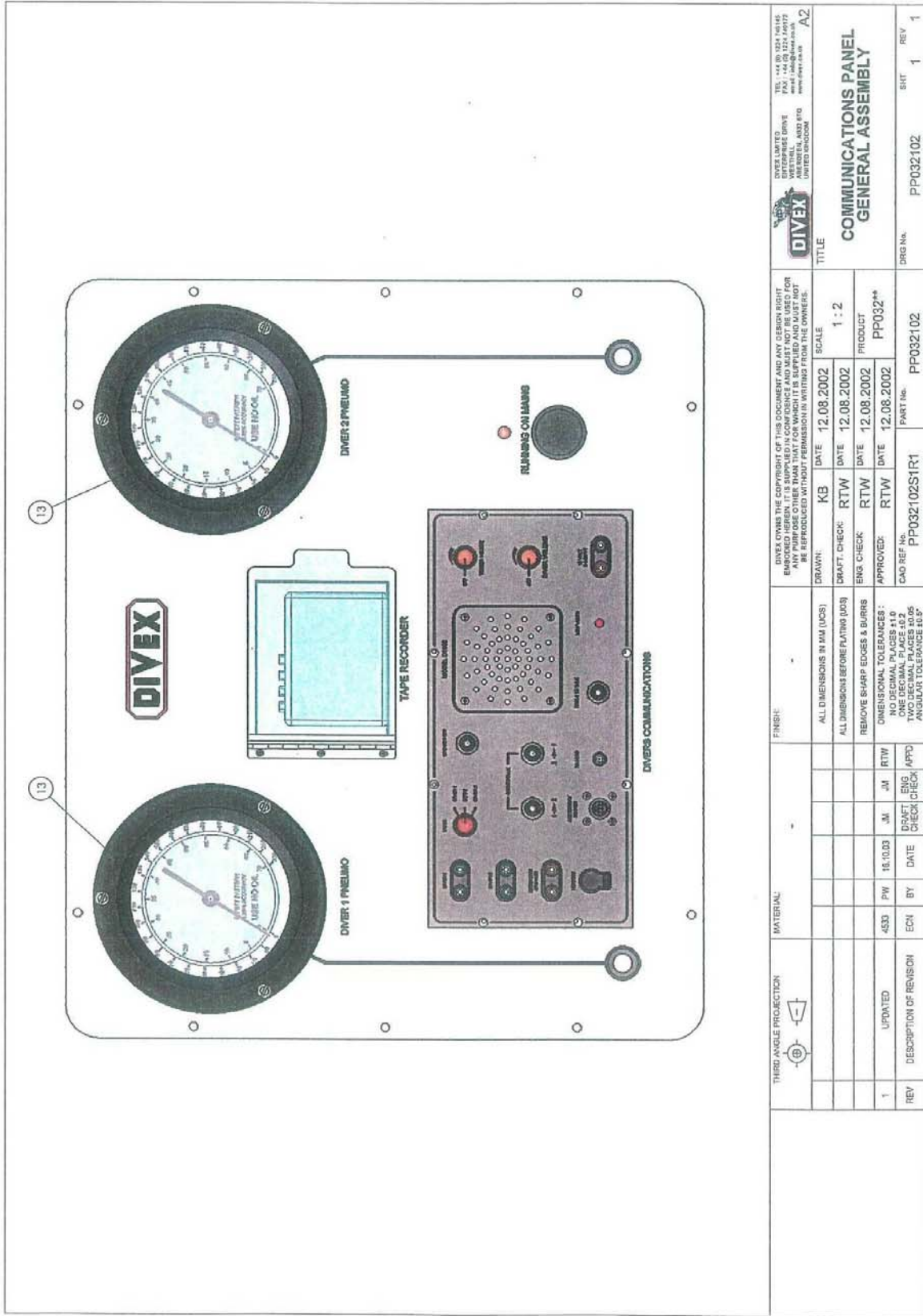

THIRD ANGLE PROJECTION		MATERIAL		FINISH		DRAWN: KB DATE 12.08.2002 SCALE 1:2		DIVER COMMUNICATIONS PANEL GENERAL ASSEMBLY	
				ALL DIMENSIONS IN MM (UNLESS OTHERWISE SPECIFIED) REMOVE SHARP EDGES & BURRS DIMENSIONAL TOLERANCES: ONE DECIMAL PLACE ±0.2 TWO DECIMAL PLACES ±0.05 ANGLES TO NEAREST 5'		DRAFT CHECK: RTW DATE 12.08.2002 ENG CHECK: RTW DATE 12.08.2002 APPROVED: RTW DATE 12.08.2002 CAD REF No: PP032102S1R1 PART No: PP032102		DIVEX LIMITED ENTERPRISE DRIVE ABERDEEN AND FIFE UNITED KINGDOM TEL: +44 (0) 1224 761145 FAX: +44 (0) 1224 761172 WWW.DIVEX.CO.UK	
1	UPDATED	PW	16.10.03	JM	RTW	COMMUNICATIONS PANEL GENERAL ASSEMBLY			
REV	DESCRIPTION OF REVISION	ECN	BY	DATE	DRAFT CHECK	ENG CHECK	APPD	DRG No.	BIT
								PP032102	1

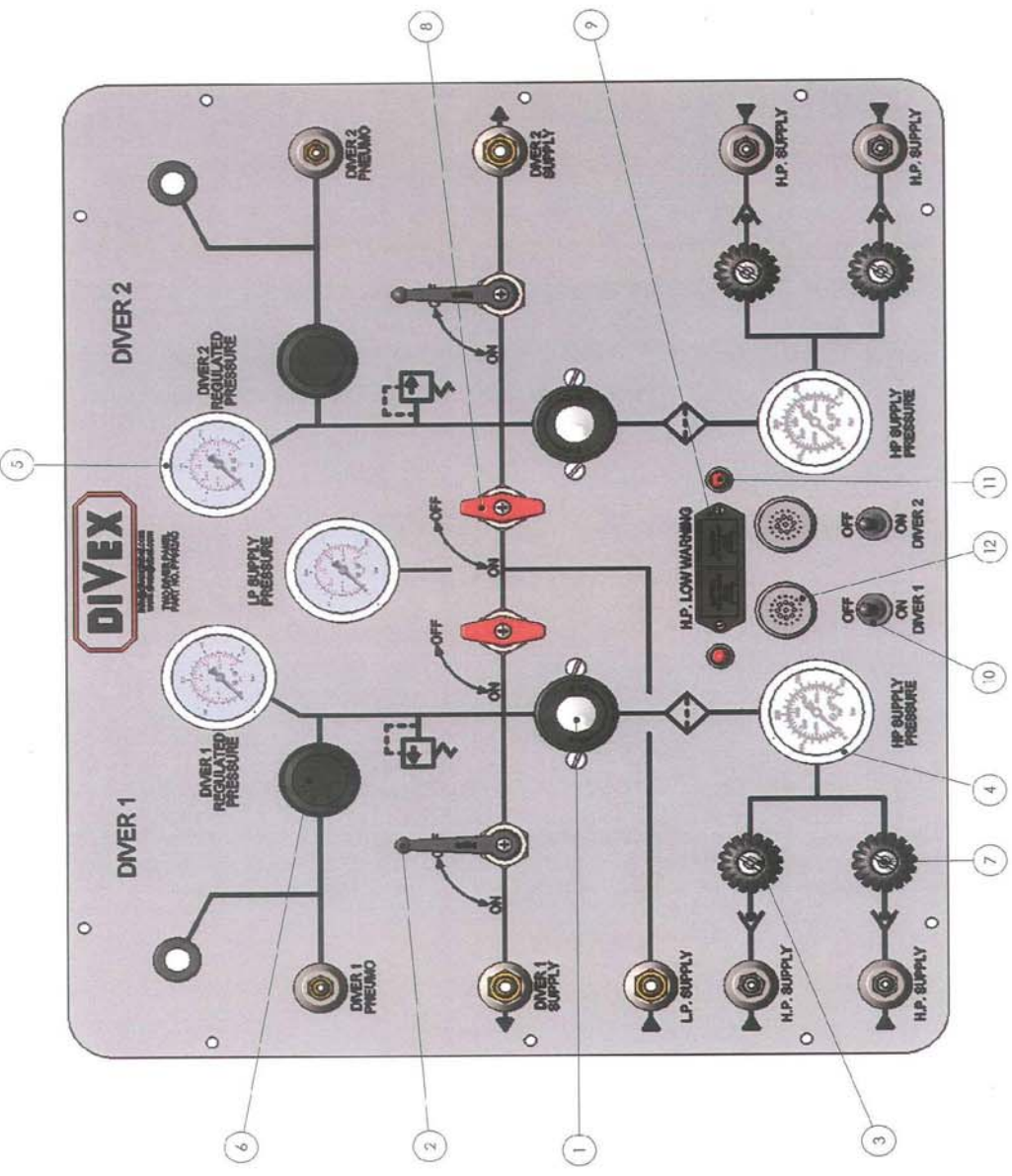

**DIVEX**  
 DIVEX LIMITED  
 ENTERPRISE DRIVE  
 WOODHILL INDUSTRIAL  
 AREA, SHELTON  
 UNITED KINGDOM  
 Tel: +44(0) 224 740 45  
 Fax: +44(0) 224 40172  
 www.divexpld.com

**DIVER AIR SUPPLY,  
 AC VARIANT,  
 GENERAL ASSEMBLY**

REV: R01  
 DRAWING No: PP032109S1  
 PRODUCT PROJECT No: PP

REV: PP  
 MET No: PP032AC  
 SIZE: A2  
 SCALE: 1.2  
 SHEET: 1 OF 1

**DO NOT SCALE DRAWING**

REV	DESCRIPTION	DATE	BY	CHECKED	DATE	BY
R01	ISSUED FOR MANUFACTURE	18/04/11	DR	DR	18/04/11	DR
R02	ADD AIR INLET GAUGE & WATERPROOF BUZZER	18/04/11	DR	DR	18/04/11	DR
R03						
R04						
R05						
R06						

**NOTES**

DIVEX OWNS THE COPYRIGHT OF THIS DOCUMENT AND ANY DESIGN RIGHT HEREIN. IT IS SUPPLIED IN CONFIDENCE AND MUST NOT BE USED FOR ANY PURPOSE OTHER THAN THAT FOR WHICH IT IS SUPPLIED AND MUST NOT BE REPRODUCED WITHOUT PERMISSION IN WRITING FROM THE OWNERS.

ALL DIMENSIONS SHOWN ARE IN MM (UOS)  
 ALL DIMENSIONS BEFORE PLATING (UOS)  
 REMOVE ALL SHARP EDGES AND BURRS

DIMENSIONAL TOLERANCES		FABRICATION	
SIZE >0	+100	ANGULAR TOLERANCE	±0.5°
SIZE >100	<500	ANGULAR TOLERANCE	±1.5°
SIZE >500	<1000	ANGULAR TOLERANCE	±3.0°
SIZE >1000	<5000	ANGULAR TOLERANCE	±6.0°
SIZE >5000	<10000	ANGULAR TOLERANCE	±12.0°

**MATERIAL**  
 N/A

**FINISH**  
 N/A

**PROJECTION**  
 THIRD ANGLE

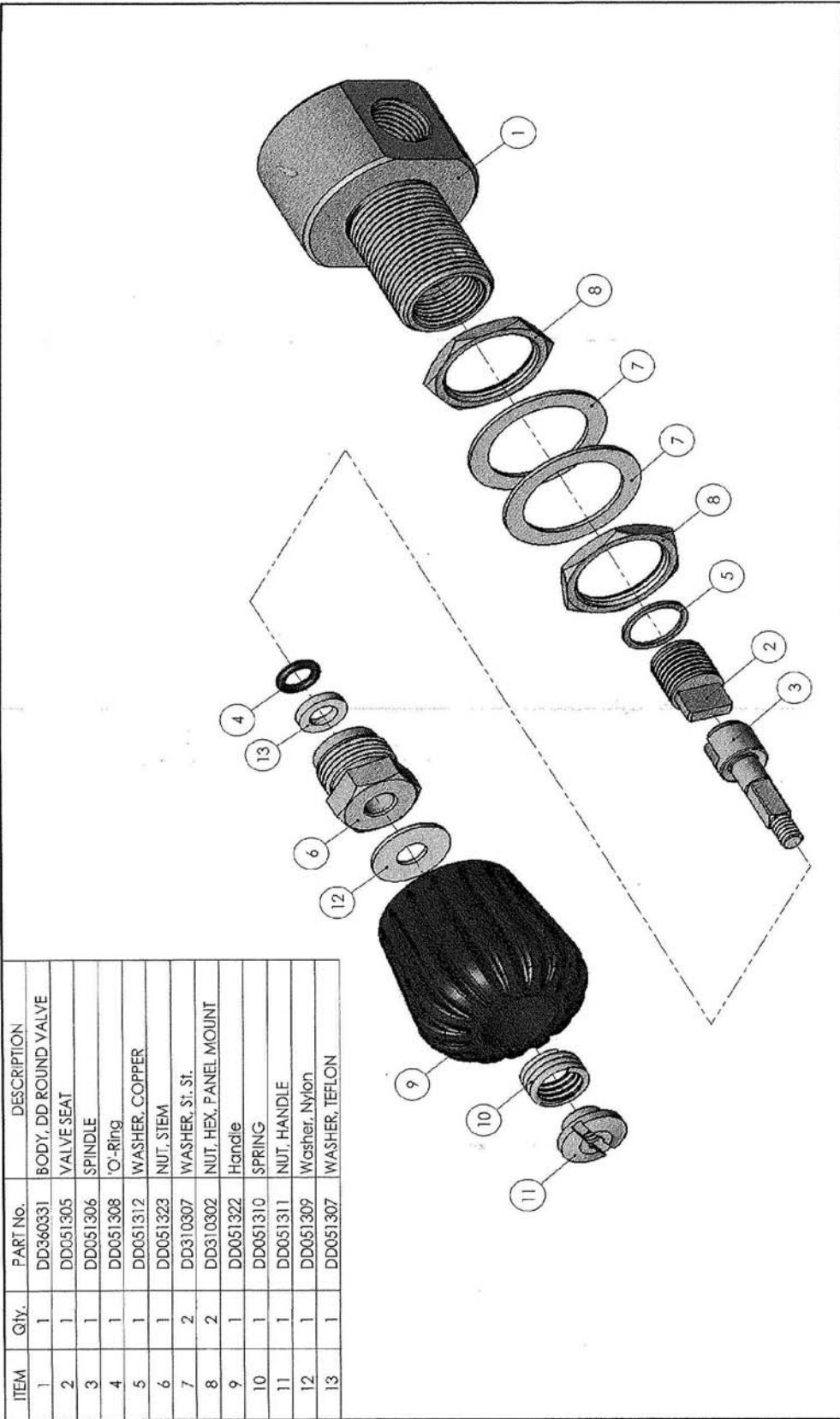

ITEM	Qty.	PART No.	DESCRIPTION
1	1	DD360331	BODY, DD ROUND VALVE
2	1	DD051305	VALVE SEAT
3	1	DD051306	SPINDLE
4	1	DD051308	O-Ring
5	1	DD051312	WASHER, COPPER
6	1	DD051323	NUT, STEM
7	2	DD310307	WASHER, St. St.
8	2	DD310302	NUT, HEX, PANEL MOUNT
9	1	DD051322	Handle
10	1	DD051310	SPRING
11	1	DD051311	NUT, HANDLE
12	1	DD051309	Washer, Nylon
13	1	DD051307	WASHER, TEFLON

THIRD ANGLE PROJECTION		MATERIAL:		FINISH:		SCALE		PRODUCT		TITLE					
6	ITEM 7 QUANTITY INCREASED	PW	01.08.2004	RTW	1.6.04	RTW	1.6.04	DD ROUND VALVE	PANEL CONTROL VALVE ASSEMBLY, 1/4" NPT(F) PORTS						
5	COMPONENT PART No. CHANGE	KB	29.07.2002	RTW	29.07.2002	RTW	29.07.2002	NTS	DD360135						
4	REDRAWN ON SOLIDWORKS	AJB	12.02.2002	RTW	12.02.2002	RTW	12.02.2002	PART No.	DD360135						
0	ISSUED FOR MANUFACTURE	N/A	01.12.2000	GG	07.12.2000	GG	07.12.2000	CAD REF No.	20271-6						
REV	DESCRIPTION OF REVISION	ECN	DRAWN BY	DATE	DRAFTING CHECK BY	ENGINEER CHECK BY	DATE	APPROVAL BY	DATE	DRG No.	U1011	SHT	1	REV	6

DIVEX LIMITED  
 DIVEX HOUSE DRIVE  
 ABERDEEN AB22 8TD  
 UNITED KINGDOM  
 TEL: +44 (0)1224 760145  
 FAX: +44 (0)1224 760142  
 email: sales@divex.co.uk  
 www.divex.co.uk

DIVEX OWNS THE COPYRIGHT OF THIS DOCUMENT AND ANY DESIGN RIGHT EMPLOYED HEREIN. IT IS SUPPLIED IN CONFIDENCE AND MUST NOT BE USED FOR ANY PURPOSE OTHER THAN THAT FOR WHICH IT IS SUPPLIED AND MUST NOT BE REPRODUCED WITHOUT PERMISSION IN WRITING FROM THE OWNERS.

ALL DIMENSIONS IN MM (UNLESS STATED OTHERWISE)  
 ALL DIMENSIONS BEFORE PLATING (UNLESS STATED OTHERWISE)  
 REMOVE SHARP EDGES & BURRS  
 DIMENSIONAL TOLERANCES:  
 NO DECIMAL PLACES ±1.0  
 ONE DECIMAL PLACE ±0.2  
 TWO DECIMAL PLACES ±0.06  
 ANGULAR TOLERANCE ±0.5°

1101n