

ITEM NO.	PART NUMBER	DESCRIPTION	QTY.
1	CO383300	FACIA, FRONT, CHAMBER PHONE, 2 CHANNEL	1
2	EM3365	PANEL, SIDE, 3U, 167MM DEEP, PIU4/5	2
3	CO383301	FACIA, REAR, CHAMBER PHONE, 2 CHANNEL	1
4	EM3364	PANEL, COVER, 42HP, 167MM DEEP	2
5	EM3030	SWITCH, DPST, GREEN ILLUMINATING, PANEL MOUNT	1
6	EM11575	SPEAKER, FULL RANGE, 2.5", 8 OHM	1
7	EM3358	POTENTIOMETER, LINEAR, 22K, SEALED	3
8	EM863	KNOB, COLLET, 15mm DIA, 1/4" SHAFT	1
9	EM3092	SWITCH, PUSH BUTTON, LATCHING, FLUSH, DPCO	1
10	EM3032	SWITCH, PUSH BUTTON, DPCO, MOMENTARY	1
11	EM10842	POWER INLET, IEC TWIN FUSED	1
12	EM3359	SOCKET, PHONO, RED, GOLD CONTACT	2
13	EM2062	PSU, SWITCH MODE, TRACO, 35W, 12V	1
14	CO383302	PLATE, MOUNTING, CHAMBER PHONE	1
15	CO383100	PCB ASSEMBLY, COMMS, CHAMBER PHONE, 2 CHANNEL	1
16	EM3043	COVER, KNOB, GREY, LINED, 15MM	1
17	FB758	SCREW, BRASS, PAN HEAD, SLOTTED, M6 X 30MM	1
18	FN081	NUT, FULL, HEX, BRASS, M6	3
19	FB169	SCREW, M/C, CSK, SCKT, M3 X 10, S316	4
20	EM3512	SPACER, NYLON, 5MM LG, 4.2MM ID	4
21	FN089	NUT, NYLOC, M3, 316 ST STEEL	6
22	FB825	SCREW, M/C, CSK, POZIDRIVE, M2.5 X 5MM, SS 316	12
23	FN078	NUT, NYLOC, M4, 316 ST STEEL	8
24	FB510	SCREW, M3 X 12MM LG, PAN HD, SLOTTED, SS316	10
25	EM3355	SOCKET, PANEL, AMPHENOL, 6 P + E, 10A, IP67	3
26	EM1121	NUT COVER, COLLET KNOB, 15mm	1
27	EM3356	DUST CAP, FEMALE RECEPTACLE, AMPHENOL (ECOMATE)	3
28	EM877	SWITCH, ROTARY, 4 POLE, 3 POSITION	1
29	EM183	MICROPHONE, ELECTROSTATIC	1
30	CO435300	MOUNT, MICROPHONE, PANEL	1
31	CO435304	INSERT, MICROPHONE MOUNT, PANEL	1
32	RN0610-7	O-RING	1
33	FW169	WASHER, PLAIN, M14, SS	1
34	FN332	NUT, HEX, HALF, ST ST.A4, M14	1
35	FB168	SCREW, M/C, PAN HD, M4 X 12, 316L ST. STEEL	4
36	FB829	SCREW, M/C, PAN, POZIDRIVE, M3 X 12MM, BLACK	6
37	FB285	SCREW, M/C, PAN HD, M4 X 20 LONG	4

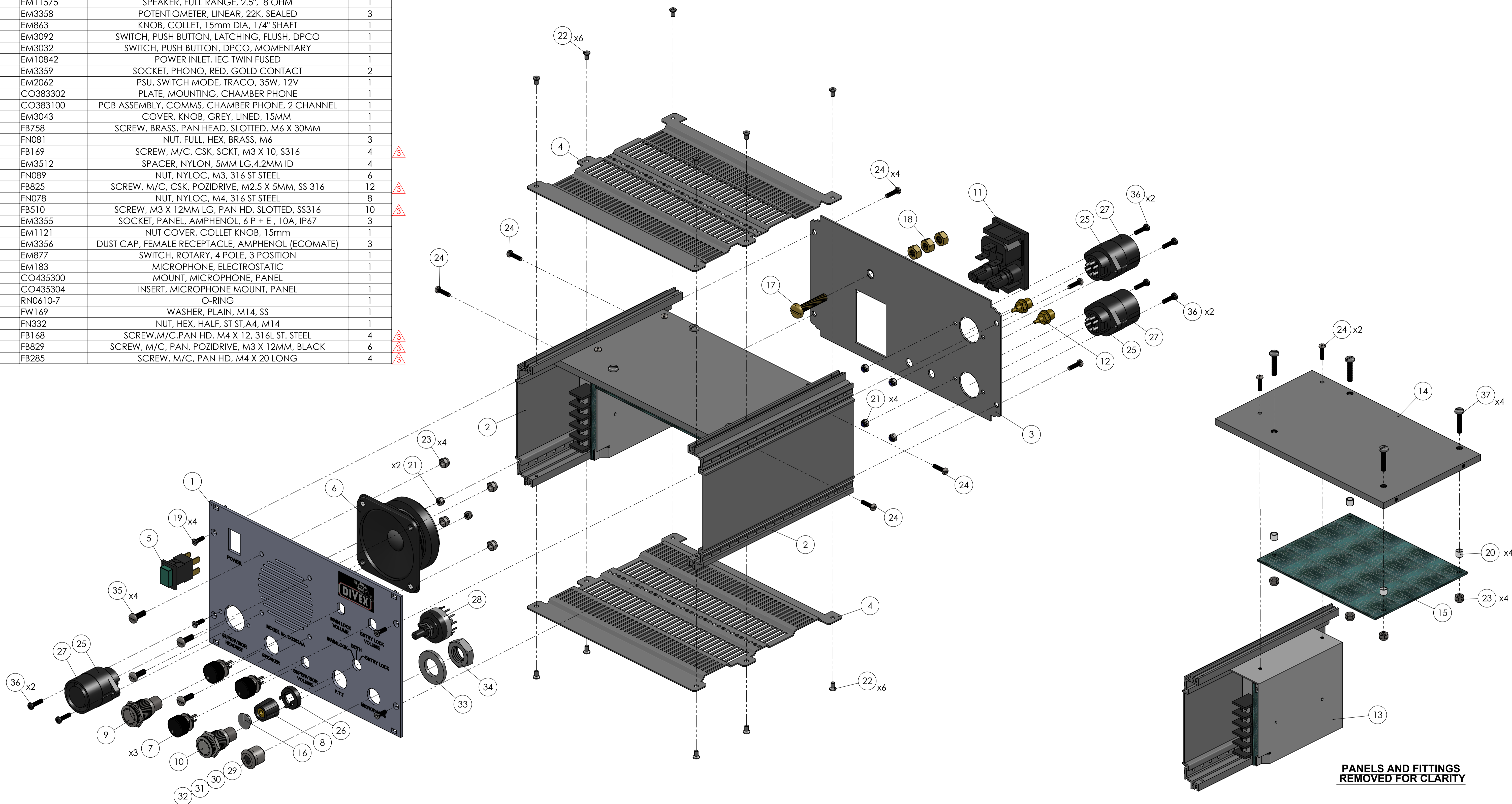

DIVEX OWNS THE COPYRIGHT OF THIS DOCUMENT AND ANY DESIGN RIGHT HEREIN. IT IS SUPPLIED IN CONFIDENCE AND MUST NOT BE USED FOR ANY PURPOSE OTHER THAN THAT FOR WHICH IT IS SUPPLIED AND MUST NOT BE REPRODUCED WITHOUT PERMISSION IN WRITING FROM THE OWNERS.

NOTES

△ - DENOTES CHANGES MADE AT THIS REVISION.

ALL DIMENSIONS SHOWN ARE IN MM (UOS)			
ALL DIMENSIONS BEFORE PLATING (UOS)			
REMOVE ALL SHARP EDGES AND BURRS			
DIMENSIONAL TOLERANCES			
MACHINING		FABRICATION	
NO DECIMAL PLACES	±1.0	SIZE >0 <100	±0.5
ONE DECIMAL PLACE	±0.2	SIZE >100 <500	±1.5
TWO DECIMAL PLACE	±0.05	SIZE >500	±3.0
ANGULAR TOLERANCE	±0.5°	ANGULAR TOLERANCE	±0.5°

MATERIAL	SEE PARTS LIST
FINISH	N/A
 THIRD ANGLE PROJECTION	

REV	DESCRIPTION	ECN No	BY	DATE	AUTH BY
R06					
R05					
R04					
R03	DESIGN CHANGE	15395	ZD	29/01/2013	SC
R02	PARTS LIST UPDATED	15252	ZD	07/11/2012	SC
R01	DESIGN CHANGE	14812	ZD	13/07/2012	SC
R00	ISSUED FOR MANUFACTURE		ZD	12/07/2012	C. S-T

DO NOT SCALE DRAWING

<h2>CHAMBER PHONE , 2 CHANNEL</h2>			
DRAWING No.	REV		
<b>CO38311S1</b>	<b>R03</b>		
PART No.	PRODUCT / PROJECT No.		
<b>CO383AA</b>	<b>COMMS</b>		
SIZE	SCALE	SHT	OF
A1	1 : 1.5	1	1

DIVEX LIMITED  
 ENTERPRISE DRIVE  
 WESTHILL  
 ABERDEEN  
 AB32 6TQ  
 UNITED KINGDOM  
 Tel : +44(0)1224 740145  
 Fax : +44(0)1224 740172  
 email : info@divexglobal.com  
 www.divexglobal.com