

| ITEM | PART No. | DESCRIPTION | QTY |
|------|----------|--|-----|
| 1 | CO439100 | ENCLOSURE, COMMS BOX, BELL | 1 |
| 2 | EM30420 | END STOP, DIN TERMINAL, FUSED & FEED THROUGH | 2 |
| 3 | EM32387 | TERMINAL, 2.5 SAK | 4 |
| 4 | EM32388 | END PLATE, TERMINAL, SAK 2.5 | 1 |
| 5 | EM34297 | EARTH TERMINAL, 2.5mm, EK 2.5/35 | 2 |
| 6 | CO140 | MICROPHONE, POWER, NFES SPEC | 1 |
| 7 | EM3267 | SWITCH, PUSH BUTTON, SPNO, MOMENTARY, IP66 | 1 |

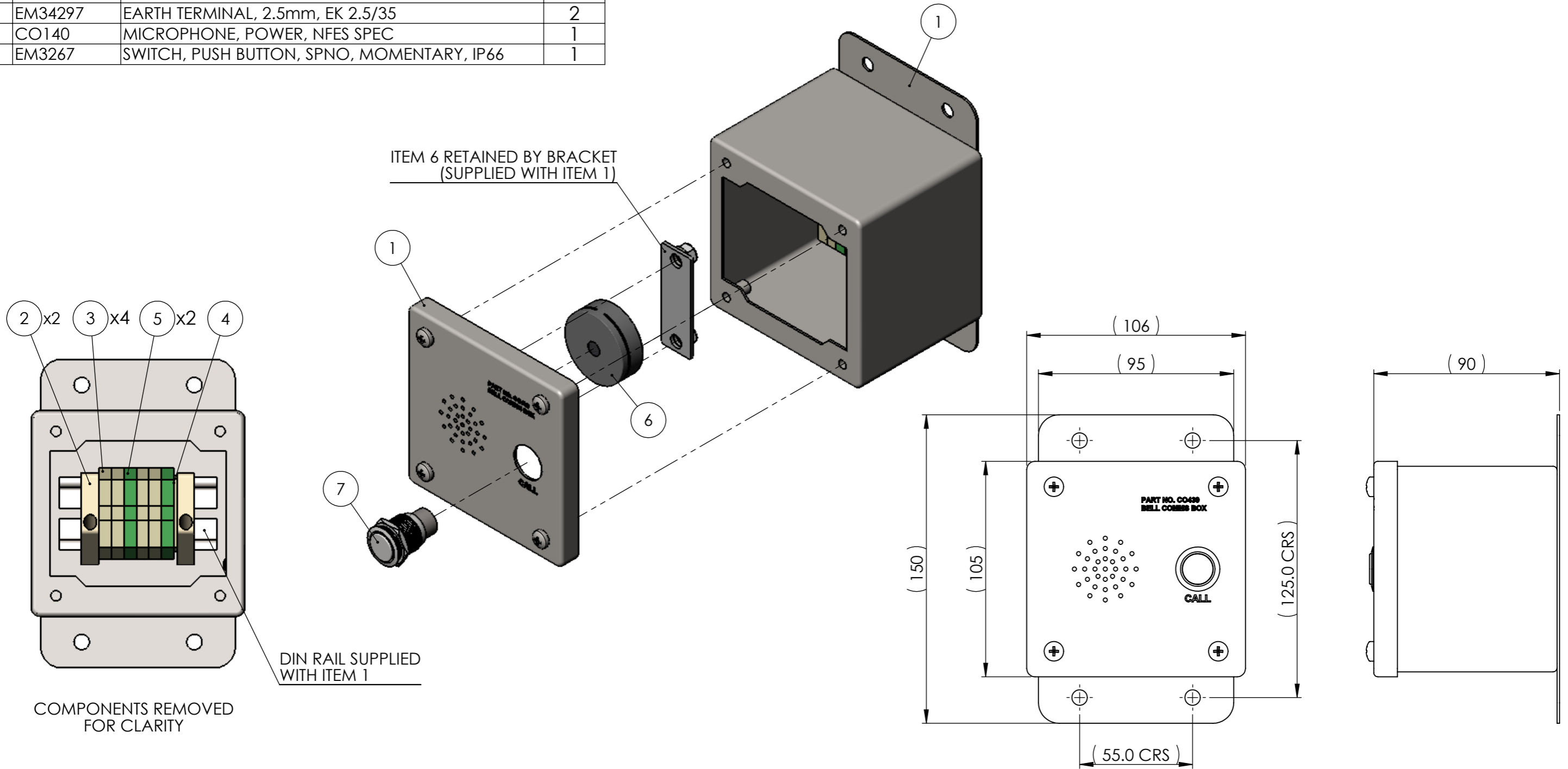

DIVEX OWNS THE COPYRIGHT OF THIS DOCUMENT AND ANY DESIGN RIGHT HEREIN. IT IS SUPPLIED IN CONFIDENCE AND MUST NOT BE USED FOR ANY PURPOSE OTHER THAN THAT FOR WHICH IT IS SUPPLIED AND MUST NOT BE REPRODUCED WITHOUT PERMISSION IN WRITING FROM THE OWNERS.

| | | | | | | | | | | | |
|---|---|------------------------|------------------------|---------|----|-----------------------|----------|-------------------------|-------|-------|----|
| ALL DIMENSIONS SHOWN ARE IN MM (UOS) ALL DIMENSIONS BEFORE PLATING (UOS) REMOVE ALL SHARP EDGES AND BURRS | MATERIAL | SEE PARTS LIST | | | | TITLE | | BOX, COMMS, BELL | | | |
| | FINISH | N/A | | | | DRAWING No. | | CO439S1 | | | |
| DIMENSIONAL TOLERANCES MACHINING NO DECIMAL PLACES ±1.0 ONE DECIMAL PLACE ±0.2 TWO DECIMAL PLACE ±0.05 ANGULAR TOLERANCE ±0.5° | FABRICATION SIZE >0 <100 ±0.5 SIZE >100 <500 ±1.5 SIZE >500 ±3.0 ANGULAR TOLERANCE ±0.5° | THIRD ANGLE PROJECTION | | | | PART No. | | CO439 | | | |
| | | DO NOT SCALE DRAWING | | | | PRODUCT / PROJECT No. | | COMMS | | | |
| | | REV | DESCRIPTION | ECN No. | BY | DATE | AUTH. BY | SIZE | SCALE | SHEET | OF |
| | | R06 | | | | | | A3 | 1:2 | 1 | 1 |
| | | R05 | | | | | | | | | |
| | | R04 | | | | | | | | | |
| | | R03 | | | | | | | | | |
| | | R02 | | | | | | | | | |
| | | R01 | | | | | | | | | |
| | | R00 | ISSUED FOR MANUFACTURE | | JG | 28/09/10 | CC | | | | |

DIVEX

DIVEX LIMITED
 ENTERPRISE DRIVE
 WESTHILL
 ABERDEEN
 AB32 6TQ
 UNITED KINGDOM

Tel : +44(0)1224 740145
 Fax : +44(0)1224 740172
 email : info@divexglobal.com
 www.divexglobal.com