

ITEM NO.	PART NO.	DESCRIPTION	QTY.
1	LA360100	HEAD, ASSEMBLY, LED BUNKLIGHT	1
2	LA360101	SWITCH, ASSEMBLY, LED BUNKLIGHT	1
3	LA3603005	SCREW, SOCKET CAP, M10X1, MODIFIED, 14MM	1
4	FW125	WASHER, M10, FORM A, 316SS	1
5	FB793	SCREW, CAP, SOCKET, M3 X 0.5, 5MM LG, 316 ST ST	1
6	LA3603019	PCB ASSY. LED DRIVER CIRCUIT, 266MA	1
7	LA3603030	SCREW, CSK SLOTTED, M6 X 50MM LG, XYLAN BLACK 20µM	2
8	FW123	WASHER, M6, FORM A, 316L ST. STEEL	2
9	FN036	NUT, NYLOC, M6, 316L ST. STEEL	2
10	LA3603007	BASE, LED BUNKLIGHT	1
11	SY104231	SWITCH, REED, PAYLOAD BAY DOOR	1
12	LA3603013	SCREW, SOCKET CAP, M3 X 5MM LG, BLACK XYLAN 20µM	3
13	CL3397	WIRE, CRIMPED, 26AWG, 150MM LONG, BLACK	1
14	EM11437	SOCKET, 2 WAY CRIMP, CONNECTOR, SURFACE MOUNT TECH (NOT SHOWN)	2
15	EM939	HEATSHRINK, BLACK, 3/1MM	1
16	EM7137	CABLE, TWISTED SCREENED PAIR, TYPE 44, 20 AWG	1
17	FB501	SCREW, M3 X 10MM LG, PAN HD, POZIDRIVE, SS316	2
18	LA3603021	RETAINING BAR, CABLE	1
19	EM3861	WASHER, PLAIN, M3, VULCANISED FIBRE, RED	1

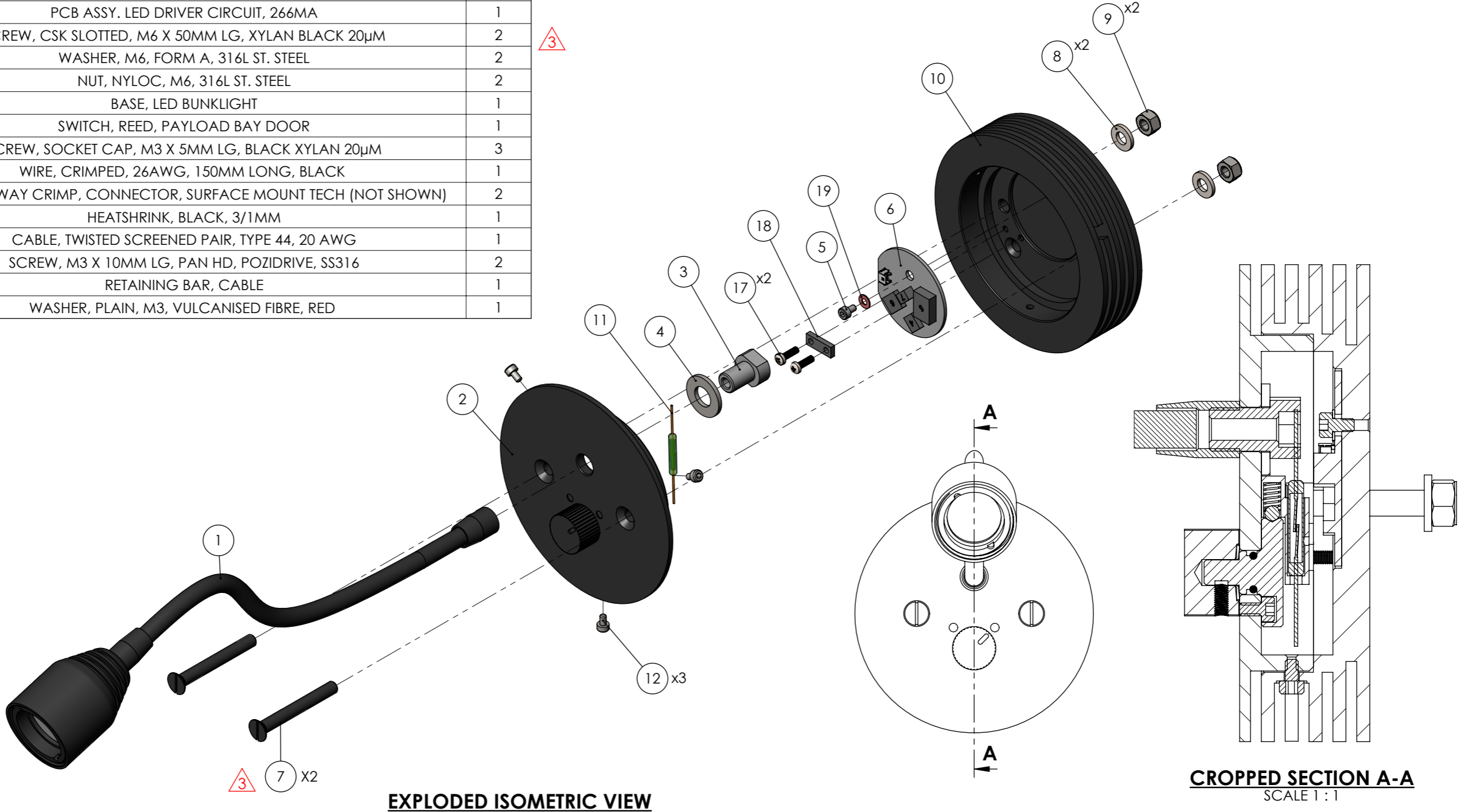

**EXPLODED ISOMETRIC VIEW**

**CROPPED SECTION A-A**  
SCALE 1 : 1

NOTES:

MATERIAL	SEE PARTS LIST
FINISH	N/A
ALL DIMENSIONS ARE IN mm (UOS) ALL DIMENSIONS BEFORE PLATING (UOS) REMOVE ALL SHARP EDGES AND BURRS	
MACHINING TOLERANCE	FABRICATION TOLERANCE
NO DECIMAL PLACE	±1.0 >0 <100 ±0.5
ONE DECIMAL PLACE	±0.2 >100 <500 ±1.5
TWO DECIMAL PLACE	±0.05 >500 ±3.0
ANGULAR TOLERANCE ±0.5°	

<p><b>3</b> DENOTES CHANGES MADE AT THIS REVISION</p>						
R03	LA3603015 REPLACED WITH LA3603030	20465	ZD	15/03/17	MH	
R02	DRAWING UPDATED & ITEM 19 ADDED	19067	MJ	12/04/16	MH	
R01	ITEM 1 UPDATED & SHEET 2 ADDED	16958	JJM	22/09/14	SW	
R00	ISSUED FOR MANUFACTURE		CC	20/08/08	SW	
REV	DESCRIPTION	ECN	BY	DATE	AUTH.	
			DO NOT SCALE DRAWING			
<small>JFD OWNS THE COPYRIGHT OF THIS DOCUMENT AND ANY DESIGN RIGHT HEREIN. IT IS SUPPLIED IN CONFIDENCE AND MUST NOT BE USED FOR ANY PURPOSE OTHER THAN THAT FOR WHICH IT IS SUPPLIED AND MUST NOT BE REPRODUCED WITHOUT PERMISSION IN WRITING FROM THE OWNERS.</small>						

TITLE				<b>LED BUNKLIGHT C/W BASE</b>		
DRAWING NO.		REV				
<b>LA360001S1</b>		<b>R03</b>				
PART NO.		PRODUCT / PROJECT No.				
LA360AA		AQUABEAM				
SIZE		SCALE (UOS)		SHEET		
A3		1:2		1 OF 2		

**JFD**  
JFD WESTHILL  
ENTERPRISE DRIVE,  
WESTHILL, ABERDEEN,  
AB32 6TQ, UK  
TEL: +44 (0)1224 740145  
E: enquires@jfdglobal.com  
W: jfdglobal.com